

CONTEMPORARY



toscanstucchi

ARTE IN OPERA

LO STILE
CONTEMPORANEO
ATTRAVERSO
IL GESSO
CONTEMPORARY
STYLE
WITH
PLASTER



toscanstucchi
ARTE IN OPERA

INDEX



- 6 PANNELLI DECORATIVI TRIDIMENSIONALI
TRIDIMENSIONAL DECORATIVE PANELS
- 30 CONTROPARETI INTERNE
E CONTROSOFFITTI DECORATIVI
DECORATIVE INTERNAL WALLS AND FALSE CEILINGS
- 36 BOISERIE
BOISERIE
- 50 QUADRI DECORATIVI
DECORATIVE TILES
- 54 CAMINETTI IN GESSO CERAMICO
CERAMIC PLASTER FIREPLACES
- 58 ILLUMINAZIONE
LIGHTING
- 72 SGUSCI
COVING ELEMENTS
- 76 CORNICI
FRAMES
- 84 BATTISCOPA
SKIRTING BOARDS

DESIGN INNOVATIVO ED EVOCAZIONI DELLA TRADIZIONE ARTIGIANA

In oltre quarant'anni di attività ed esperienza la ASF Enterprise - Toscan Stucchi si è fatta conoscere in Italia e all'Estero per i suoi prodotti, che hanno contribuito ad arredare ambienti classici ed eleganti, dal comune appartamento a ville, residenze, palazzi storici e opere di grande importanza storico-architettonica. Questa nuova pubblicazione vuole proporre prodotti nuovi e contemporanei, con lo scopo di ampliare la propria gamma di articoli e con l'ambizione di offrire nuovi spunti al progettista, sempre più esigente ed attento. Si è creata una collezione di prodotti esclusivi che coniuga ricerca ed eleganza formale, design innovativo ed evocazioni della tradizione artigiana.

Dal confronto di idee ed esperienze sono nati prodotti di stile moderno, utilizzabili in contesti molto diversi tra loro che reinterpretano con una nuova energia estetica gli spazi da arredare. Tra le principali espressioni di questi nuovi prodotti troviamo i pannelli decorativi tridimensionali e le boiserie. Con il loro design contemporaneo, valorizzato dall'abbinamento con altri elementi come battiscopa e marcapiani con l'integrazione LED, danno impulso ad una progettazione creativa e decisamente innovativa.

INNOVATIVE DESIGN AND THROUGH ARTISAN TRADITION

ASF Enterprise - Toscan Stucchi, in more than forty years of activity and experience has become known in Italy and abroad thanks to its products, which have contributed in decorating classic and elegant environments, from simple apartments to villas, residences, historical palaces and works of great historical-architectural importance. This new publication wants to propose new and contemporary products, with the aim of widening its range of articles and offering new ideas to the designer, who is more and more demanding and attentive. A collection of exclusive products was created; it combines research and formal elegance, innovative design and through artisan tradition. The confrontation of ideas and experiences led to the creation of modern style products, useable in very different contexts, which reinterpret with new aesthetic energy the spaces to be decorated. Among the main expression of these new products we find tridimensional decorative panels and boiserie. With their contemporary design, valorised by the combination with other elements such as skirting boards and string-courses with the integration of LEDs, give impulse to a creative and absolutely innovative design.



SE
GE
NO
NO

NOVOGES

LA NUOVA TECNOLOGIA TOSCAN STUCCHI
PER LE PARETI TRIDIMENSIONALI ECOSOSTENIBILI
A BASSO IMPATTO AMBIENTALE

PIU' TERMICITÀ

migliora la tenuta di caldo e freddo negli ambienti

- salvaguardia della temperatura ambientale
- risparmio energetico
- minore conducibilità termica
- maggiore resistenza termica

PIU' LEGGEREZZA

più leggero del gesso tradizionale

- maggiore facilità di utilizzo e di montaggio
- possibilità di applicazioni con più semplicità, anche su superfici in cartongesso

PIU' RESISTENZA

più resistente del gesso tradizionale

- impiego di gessi ceramici fibrorinforzati

**THE NEW TOSCAN STUCCHI TECHNOLOGY
FOR TRIDIMENSIONAL WALLS ECO SUSTAINABLE
WITH LOW ENVIRONMENTAL IMPACT**

MORE THERMAL CAPACITY

improves the hot and cold capacity in the rooms

- protection of room temperature
- energy saving
- less thermal conductivity
- greater thermal resistance

MORE LIGHTNESS

lighter than traditional plaster

- easier to use and assemble
- possibility of easier applications also on plasterboard surfaces

MORE RESISTANCE

more resistant than traditional plaster

- use of fibre reinforced ceramic plasters

PANNELLI DECORATIVI TRIDIMENSIONALI

TRIDIMENSIONAL DECORATIVE PANELS

In questo capitolo vengono proposti articoli realizzati con gessi ceramici particolarmente pregiati, miscelati con microfibre e fibre vegetali. Si riesce così a conferire ai manufatti importanti caratteristiche di elasticità e resistenza. Potrete rivestire le vostre pareti attingendo da una varietà di linee proprie dei nuovi modelli, scegliendo il disegno che riterrete più appropriato per valorizzare ulteriormente il vostro ambiente. Il nostro obiettivo è quello di apportare stile ed esclusività grazie ad uno studiato effetto tridimensionale, che accentua profondità e movimento.

In this chapter the articles realised with quality ceramic plasters, mixed with microfibres and vegetal fibres are proposed. This way we can confer the products important characteristics of elasticity and resistance. You can cover your walls choosing among a variety of the new model lines, choosing the design that you deem more appropriate to further valorise your environment. Our aim is to create an exclusive style thanks to a studied tridimensional effect that accentuates depth and movement.

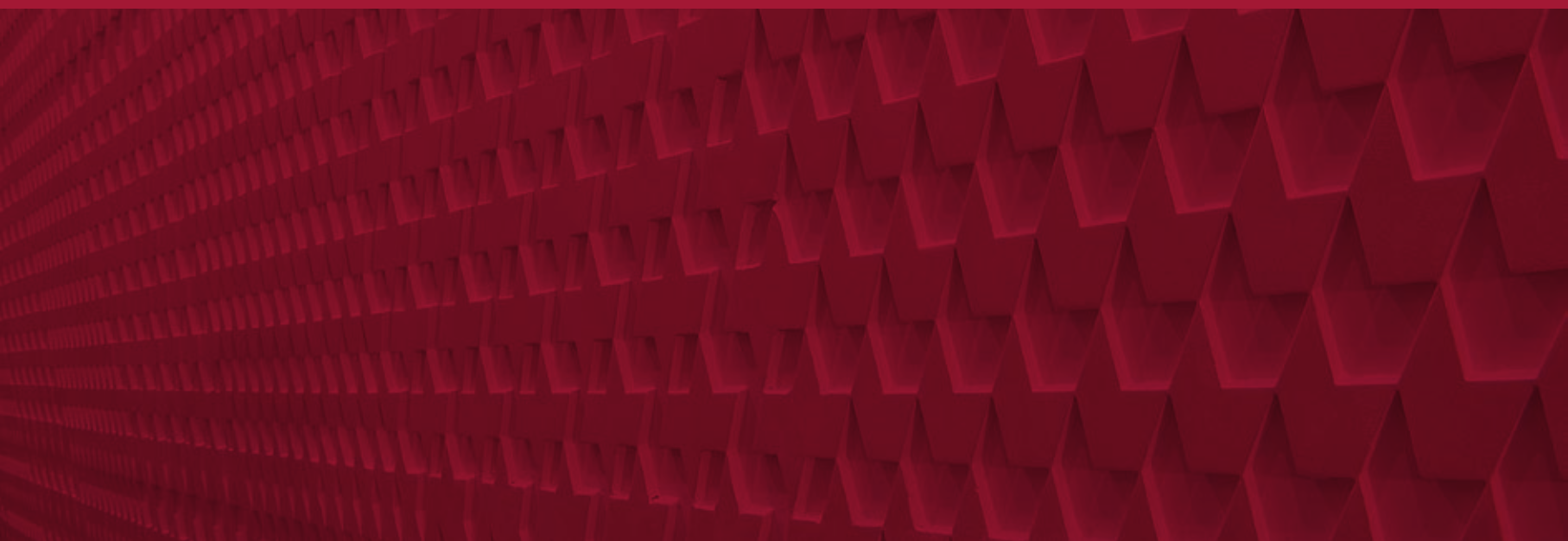



Art. FLUSSO

Design Architetto Francesca Abbruzzese

L'effetto combinato di curve sinuose incise su una superficie ondulata e fluida è capace di esprimere un senso di armonia e leggerezza.

The combined effect of sinuous curves engraved on a wavy and fluid surface expresses a sense of harmony and lightness.

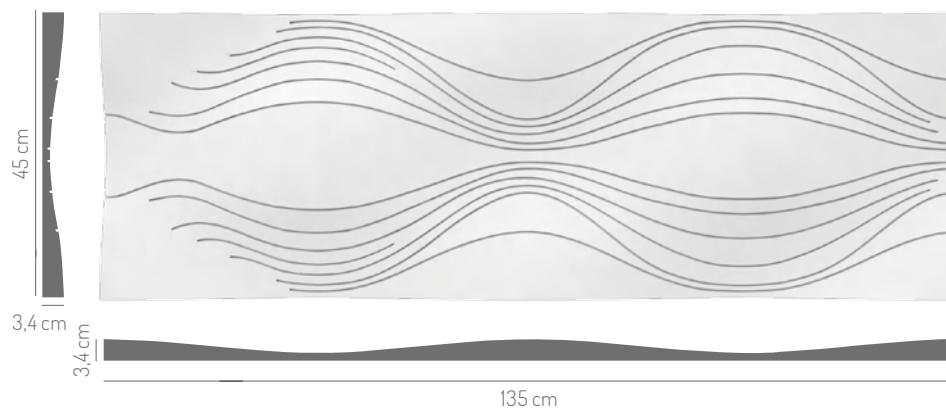



Art. CODICE

Design Architetto Francesca Abbruzzese

Una nuvola di parole in codice, che richiamano i numeri, le lettere e le principali materie studiate a scuola. Solo alcuni conoscono il significato del codice, ma possiamo farlo diventare un linguaggio comune.

A cloud of coded words, which recall numbers, letters, and the main subjects studied at school. Only a few know the meaning of the code, but we can make it become a common language.



1.2 cm

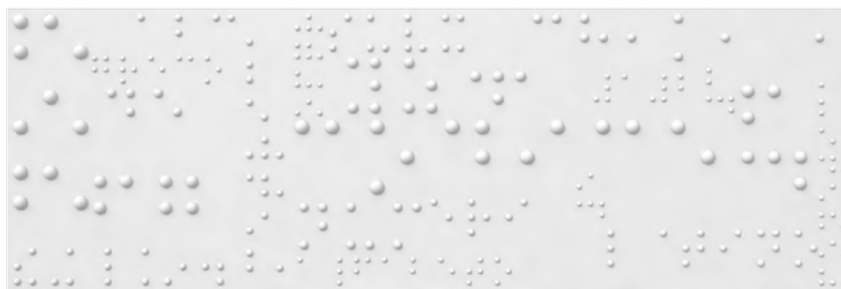

135 cm



Art. TRIFOGLIO

Design Architetto Francesca Abbruzzese

Reinterpretazione di un prato di trifogli e quadrifogli disposti nell'ordine casuale tipico della natura.

Reinterpretation of a meadow of cloverleaves and four-leaf clovers randomly arranged as in nature.

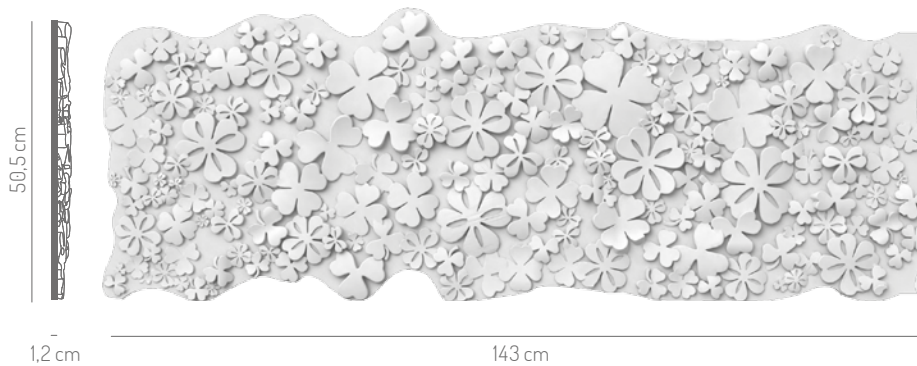

Composizione con:
Battiscopa Art. 2395
Pannello Soffio
Luce diffusa Art. 2373 LED

Composition with:
Skirting board Art. 2395
Soffio Panel
Lighting covers Art. 2373 LED







Art. SOFFIO

Design Architetto Francesca Abbruzzese

Pannello ispirato alla natura. Si è voluto realizzare un movimento fluttuante e leggero, come un dente di leone in balia del soffio del vento.

Panel inspired by nature. We wanted to realise a floating and light movement, like a dandelion in the wind.



1,2 cm



135 cm



Art. NUMERI

Design Architetto Francesca Abbruzzese

Forme geometriche che si incrociano per criptare i numeri. Vanno scoperti osservando attentamente la composizione delle forme e l'intersezione degli elementi. I numeri sono lì, ma nascosti da figure di forme essenziali.

Geometric forms that criss-cross to encrypt the numbers. They can be discovered by carefully observing the composition of the forms and crossing of the elements. The numbers are there, but hidden by essential-shaped figures.

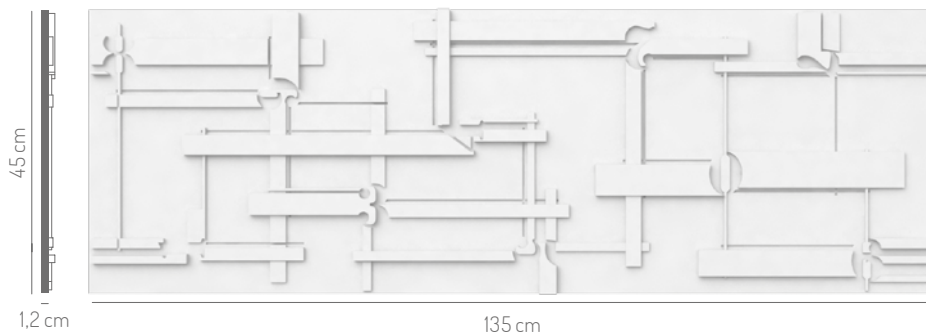



Art. SOFÀ

Ispirato alla lavorazione Capitonè, la tecnica ottocentesca di imbottitura di divani, poltrone e testate di letti, questo pannello è un ottimo elemento di contrasto tra lo stile vintage ed gli ambienti contemporanei.

It takes inspiration from the Capitonè working, the Nineteenth century technique of button-padding of sofas, armchairs, and bed headboards, this panel is an excellent contrast element between vintage style and contemporary rooms.

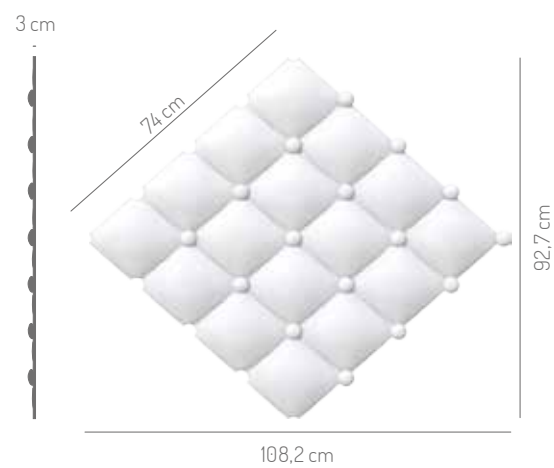



Art. SAHARA

In un movimento perpetuo il vento modella la sabbia del deserto caldo più grande al mondo, il Sahara. La natura ci ispira ancora con questo pannello dalle caratteristiche estremamente versatili, per creare un trama infinita ideale per molte soluzioni di arredo.

The wind, with a perpetual movement, models the sand of the hottest and largest desert in the world, the Sahara. Once again nature inspires us with the panel having extremely versatile characteristics, to create an infinite texture ideal for many furnishing solutions..

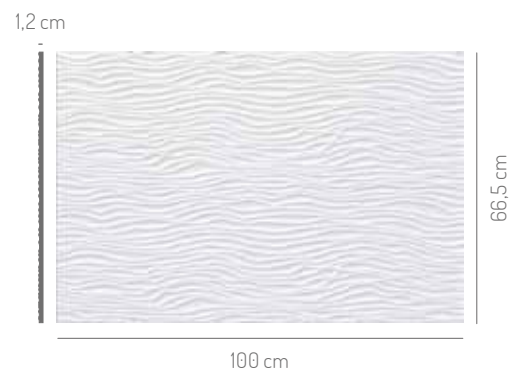

Composizione con:
Pannello Sahara
Elemento decorativo Origamini

Composition with:
Sahara Panel
Decorative Panel Origamini







Art. 4 TWEED

L'ispirazione è al tessuto pied de poule, il cui effetto colore è stato ottenuto dalla doppia profondità dei quattro motivi che decorano il pannello.

Inspiration was taken from houndstooth fabric, whose colour effect was obtained by the double depth of the four patterns that decorate the panel.

2 cm

88 cm

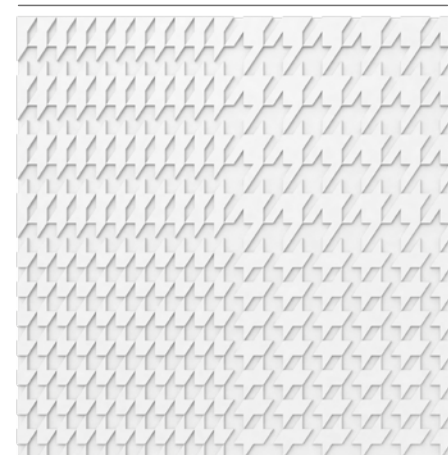

90 cm



Art. TWEED

Per evidenziare il caratteristico disegno del pied de poule, questo pannello, viene proposto con un unico motivo con doppia profondità.

This panel, to highlight the characteristic houndstooth pattern, is proposed with a unique double depth motif.

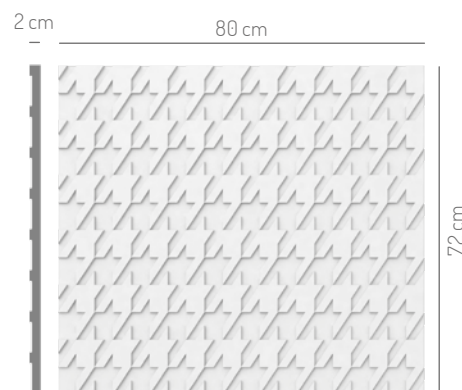



Art. POESIA

Nasce dall'idea di creare qualcosa di armonioso e continuo, un motivo ripetuto e originale per valorizzare i vostri ambienti. Predisponendo la parete ad illuminazione si ottiene un gradevole effetto. Per la manutenzione si consiglia di non applicare il pannello direttamente alla parete ma renderlo removibile con applicazioni a strappo/clip.

Result of the idea of creating something harmonious and continuous, a repeated and original pattern to valorise your rooms. Applying the lighting wall you obtain a pleasant effect. Concerning maintenance, we recommend not applying the panel directly on the wall, but making it removable with breakstem fasteners/clip.

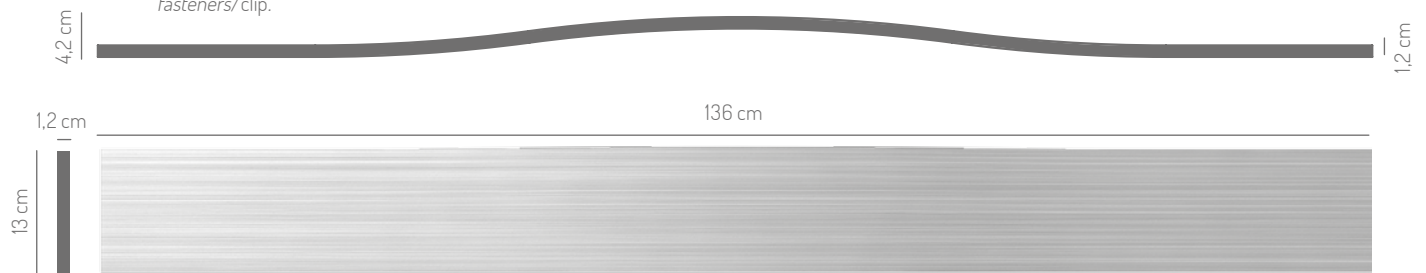

Art. RIMA

Un connubio con poesia che permette di alleggerirne il movimento armonioso senza interromperne il motivo; un effetto rigato e irregolare rende il pezzo autentico.

A mixture with poetry that allows lightening its harmonious movement without interrupting the pattern; a striped and irregular effect make the piece authentic







Art. ORIGAMI

Si ispira all'arte di piegare la carta ottenendo infinite combinazioni di luci ed ombre grazie alle quattro piegature.

It takes inspiration from the art of folding paper obtaining infinite combinations of light and shade thanks to the four folds.

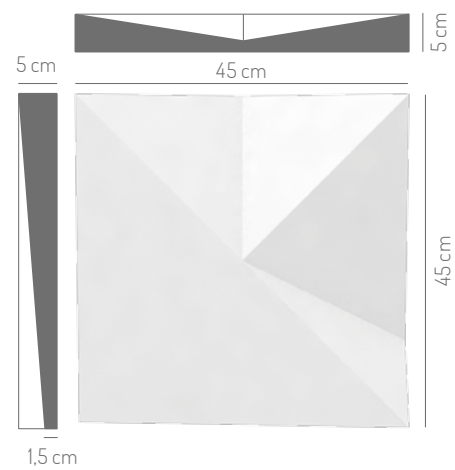



Art. ORIGAMINI

Per dare libero sfogo alla creatività ecco la versione "mini" del pannello Origami. Si possono ottenere disegni originali utilizzando solo questo pannello, oppure abbinato a Origami per aver ancor più possibilità compositive e per dare maggior risalto alla tridimensionalità.

To give free reign to creativity here is the "mini" version of the Origami panel. It is possible to obtain original designs using only this panel, or matched with Origami to have even more compositional possibilities and to accentuate more the tridimensionality.

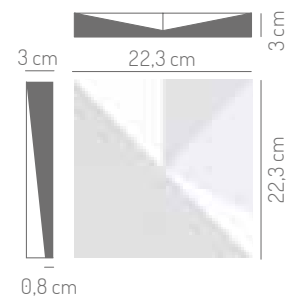



Art. TRAMA

Continua l'ispirazione al tessuto che possiamo ottenere componendo con un unico elemento ricurvo diverse combinazioni.

The inspiration taken from fabric continues, we can obtain it combining different combinations with a sole curved element.

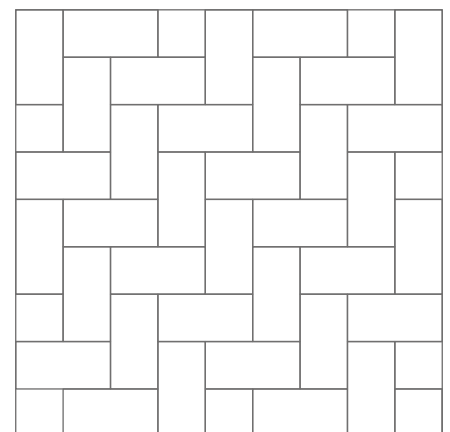
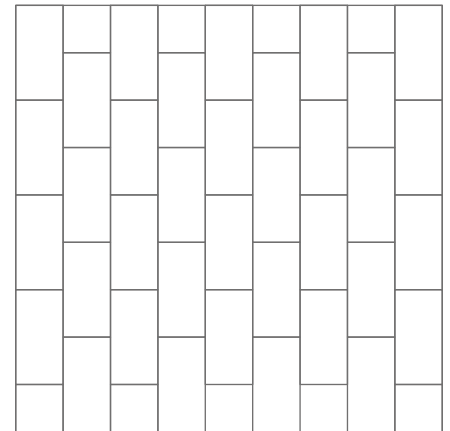
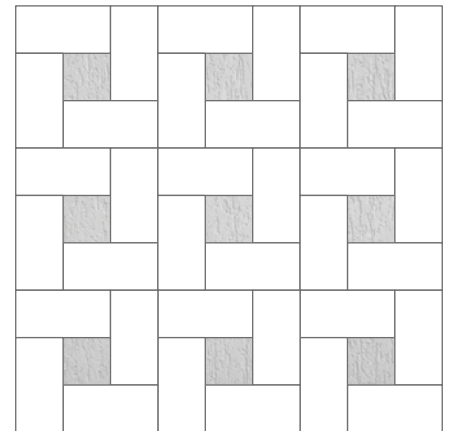
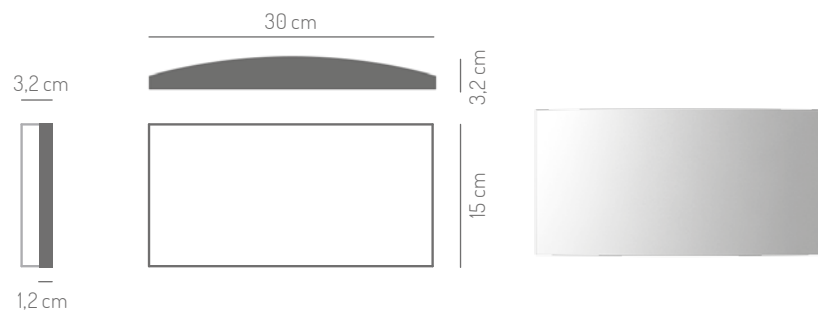

Alcuni esempi di montaggio
Mounting examples

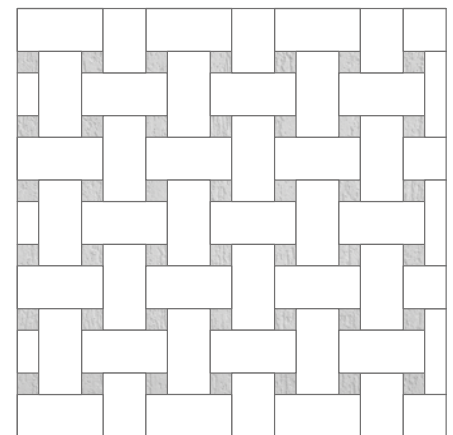
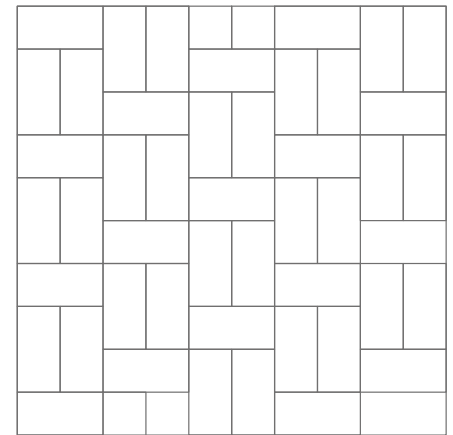
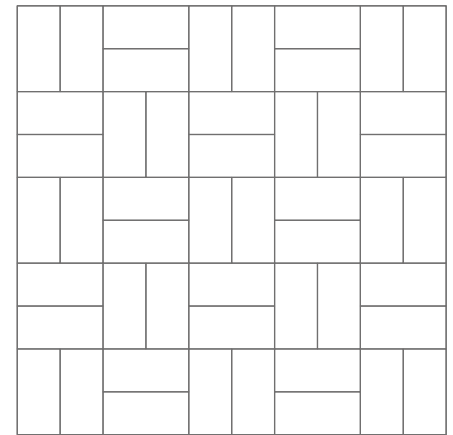

Alcuni esempi di montaggio
Mounting examples

Art. DAMA

Evoluzione di Trama, è l'effetto ottenuto da un'unica curva continua che sembra comporre, con la luce naturale, quadri più chiari alternati a quadri più scuri.

Trama Evolution, is the effect obtained by a sole continuous curve that seems to compose, with natural light, lighter tiles alternated with darker ones.

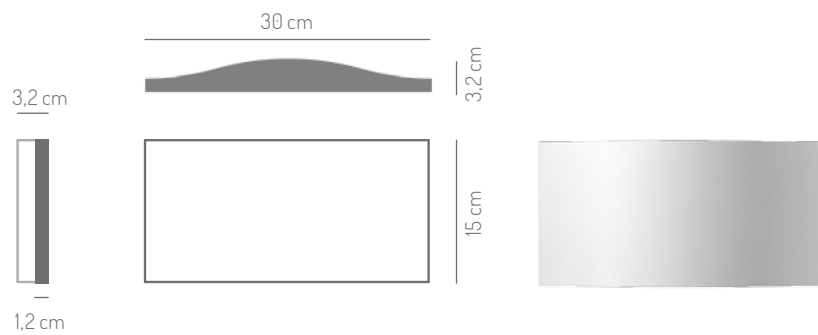





Art. WILD

Un forte richiamo alla natura nella sua versione più selvaggia. Il coccodrillo, un animale primitivo arrivato dal passato più remoto fino ai giorni nostri. Con le sue trame sempre diverse, il design di questo pannello, dona un fascino esotico agli ambienti.

A strong recall to nature in its wildest version. The crocodile, a primitive animal coming from the distant past. With its different textures, the design of this panel give the rooms an exotic appeal.



Composizione con:
Battiscopa Art. 2395
Pannello Flusso
Caminetto FS18
Quadri Art. 1838/1839
Luce diffusa Art. 2392

Composition with:
Skirting board Art. 2395
Flusso Panel
Fireplace FS18
Tiles Art. 1838/1839
Lighting coves Art. 2392







Art. VULCANO

Una decorazione puntuale, tre risalti che sembrano uscire dallo spessore del quadro, permettono di ottenere un elemento decorativo unico tra quelli finora presentati. Con Vulcano è possibile progettare una parete illuminata predisponendo faretti mono LED nelle forature da realizzare nella parte superiore di ogni cono.

A precise decoration, three reliefs that seem to come out from the thickness of the tile, which allow obtaining a unique decorative element among the ones presented up to now. With Vulcano it is possible to design an illuminated wall prearranging single LED spotlights in the holes to be realised in the upper part of each cone.

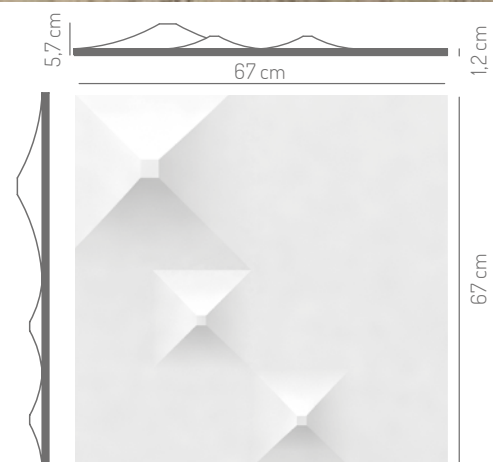



Superficie effettiva 0,52 mq / Effective area 0,52 mq

Art. GRECALE

Ricalca una muratura in pietra con sottili ricorsi.
L'irregolarità degli elementi costituenti richiama i
caratteri di un'antica produzione artigianale.

*It imitates a stone wall with thin repetitions. The
irregularity of the composing elements recalls the
characters of an ancient artisanal production.*





Superficie effettiva 0,52 mq / Effective area 0,52 mq

Art. SCIROCCO

La muratura è costituita da pietre di diverse dimensioni che riescono comunque a realizzare ricorsi orizzontali. La finitura superficiale è simile allo spacco bocciardato.

The masonry is composed of stones of different dimensions that realise horizontal repetitions. The surface finishing is similar to the bush-hammered finish.





Art. MAESTRALE

Presenta ricorsi abbastanza regolari, gli elementi sono per lo più delle stesse dimensioni e la finitura superficiale ricorda la pietra a spacco naturale.

It presents quite regular repetitions, the elements are mostly of the same dimensions and the finishing surface recalls natural split stone.

Superficie effettiva 0,65 mq / Effective area 0,65 mq

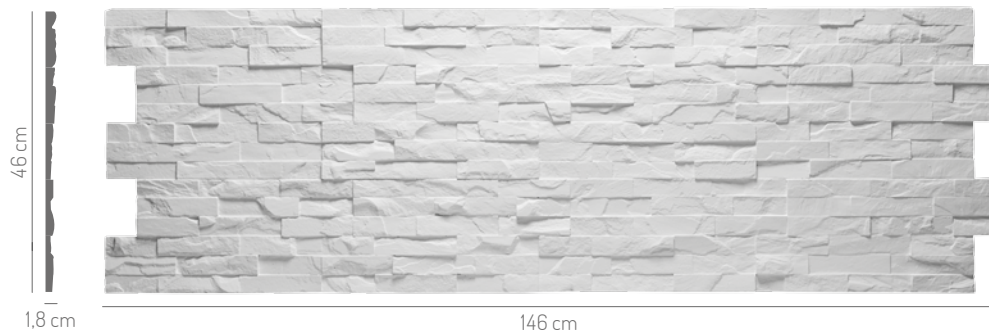



Art. LIBECCIO

Per questo pannello viene mantenuta la finitura superficiale della pietra bocciardata ma, rispetto agli altri, ha moduli quadrati e ricorsi decisamente più regolari.

The bush hammered stone surface finishing was maintained for this panel, but compared to the others it had squared modules and definitely more regular repetitions.

Superficie effettiva 0,58 mq / Effective area 0,58 mq





Art. JUGLA

Sono fasce applicabili a soffitto, come assito in legno, oppure a parete, permettendo di ottenere dei rivestimenti che si sposano bene con i pannelli murali.

They are strips that can be applied to the ceiling, like a wood partition, or on the wall, which allows obtaining coverings that match well with the wall panels.



Art. ULMO

Finta trave in gesso effetto legno con sezione a U che permette di rifinire il vostro soffitto o parete se abbinata alla fascia JUGLA. Rilevante potrebbe essere la finitura superficiale che si può ottenere con la tinteggiatura.

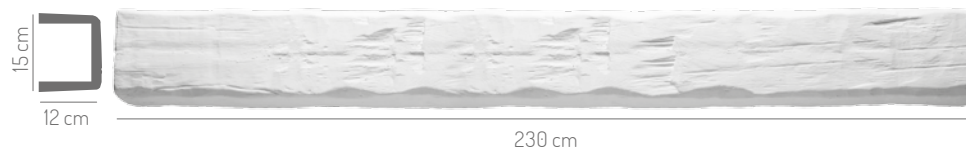

False wooden beam with U section that allows finishing your ceiling or wall if matched to the JUGLA strip. Important could be the surface finishing that can be obtained through painting.



Esempi di pannellature
allestite nel nostro
show room.

*Examples of panelling set up
in our show room.*



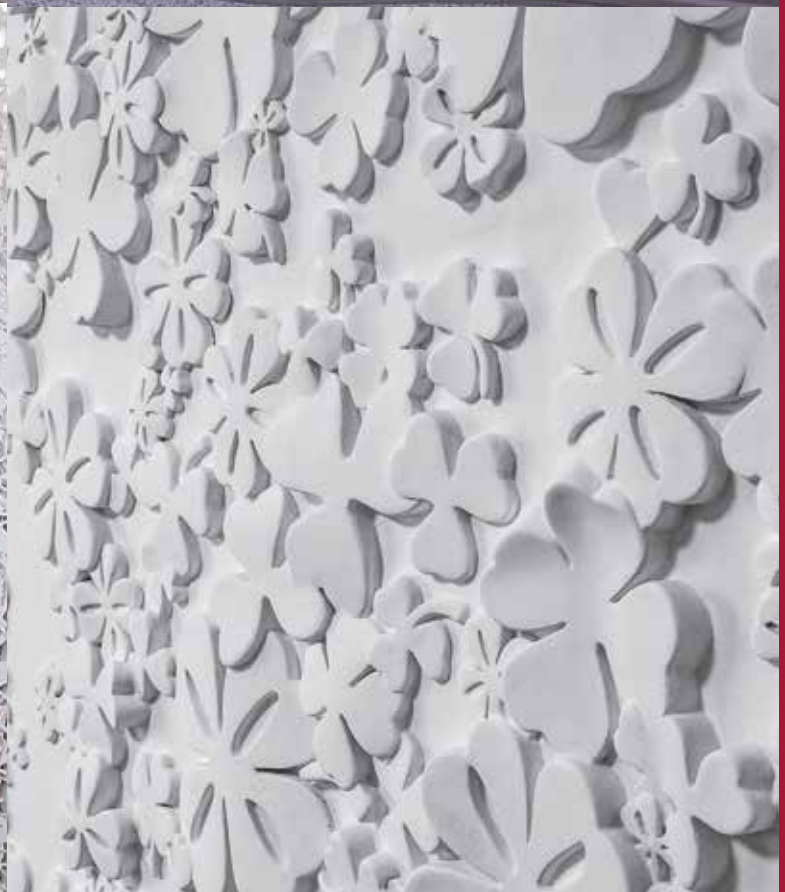
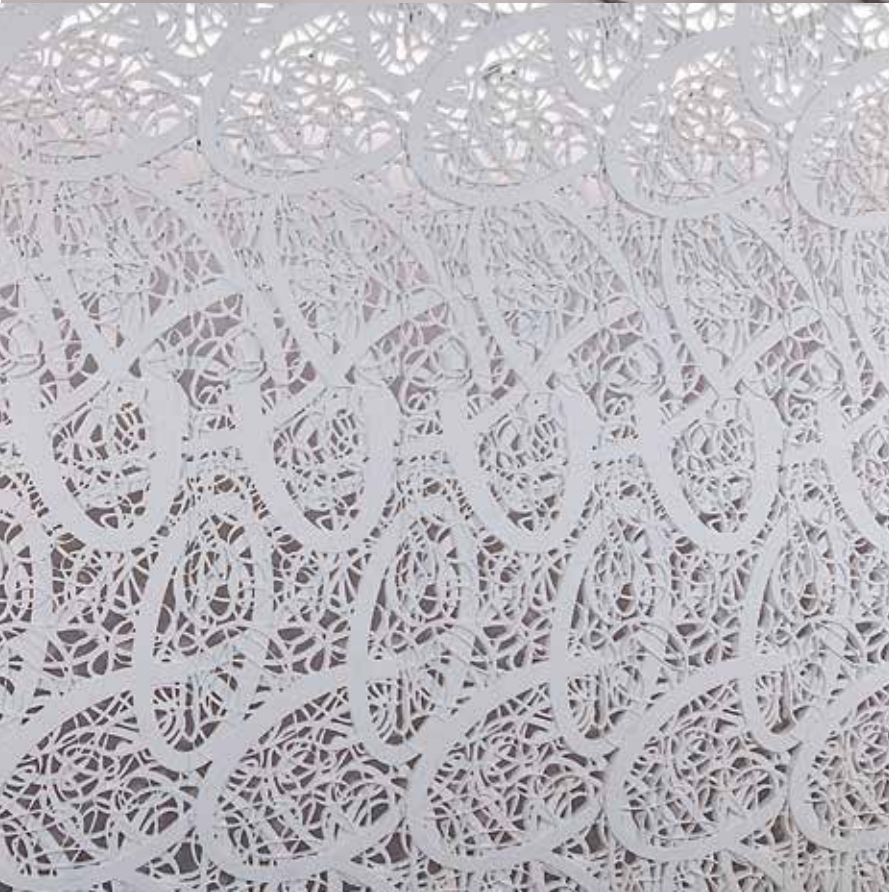

CONTROPARETI INTERNE E CONTROSOFFITTI DECORATIVI

DECORATIVE INTERNAL WALLS AND FALSE CEILINGS

Il design e le caratteristiche di questi prodotti permettono di trasformare uno spazio conferendogli importanza e prestigio, divenendo parte integrante dell'arredamento. Una particolare decorazione dei soffitti e delle pareti, integrata ai manufatti, può permettere di ottenere giochi di prospettive con effetti luce creativi ed originali.

The design and characteristics of these products allow transforming a space making it become unique and elegant, and integral part of the furnishing. A special decoration of ceilings and walls, together with other elements, allows obtaining plays of perspective with creative and original light effects.





Art. 1841

Controparete ECLISSE

Design Architetto Francesca Abbruzzese

Un gioco di ellissi che si incastrano, si abbassano e si alzano, in modo da ricreare pieni e vuoti di dimensioni diverse. Danno la possibilità di arricchire lo spazio vuoto con luce che crea un gioco d'ombre nel sottofondo.

Plays of ellipses that interlock, which lower or rise, in order to recreate solids and voids of various dimensions. They give the possibility of enriching empty space with light that creates a play of shadows in the background.

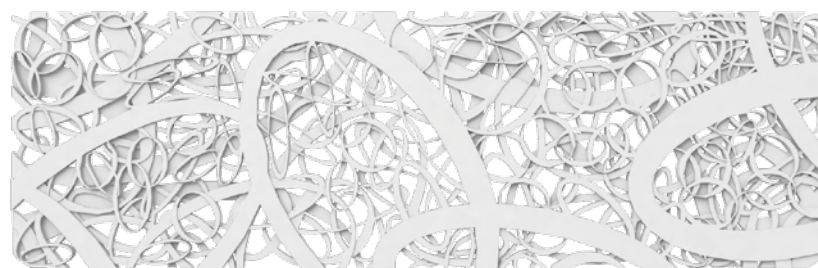
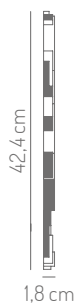

Rendering realizzato dallo
studio Baldantoni - Pesaro
Composizione con:
Colonna art. 2411
Eclisse Art. 1841
L'articolo Eclisse è stato in
questo caso commissionato
appositamente per essere
utilizzato come parete
divisoria.

*Rendering realised by studio
Baldantoni - Pesaro
Composition with:
Colonna art. 2411
Eclisse art. 1841
The Eclisse article was, in
this case, ordered to be used
expressly as partition.*







Art. 1842

ALVEARE

L'associazione è inevitabile per le sue forature esagonali. Alveare permette di realizzare un insolito controsoffitto, soprattutto se si gioca con luci e tinte particolari pensate per il contesto.

Its name is of course inspired by its hexagonal holes. Alveare allows realising an unusual false ceiling, especially if combined with lights and shades specifically created for the context.

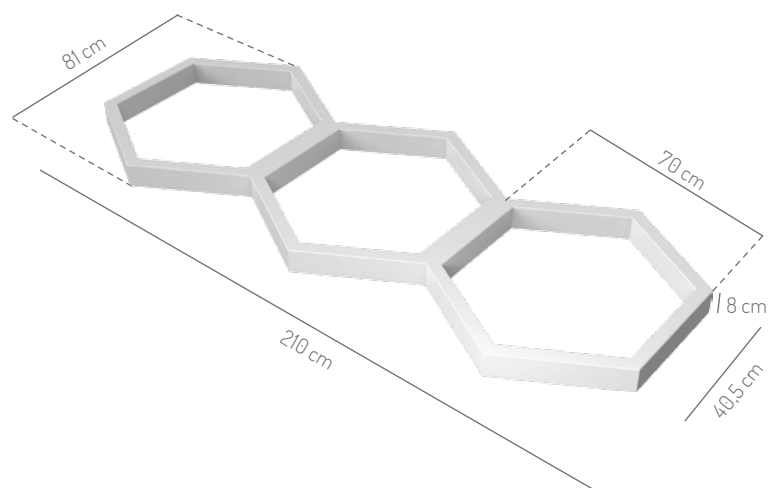

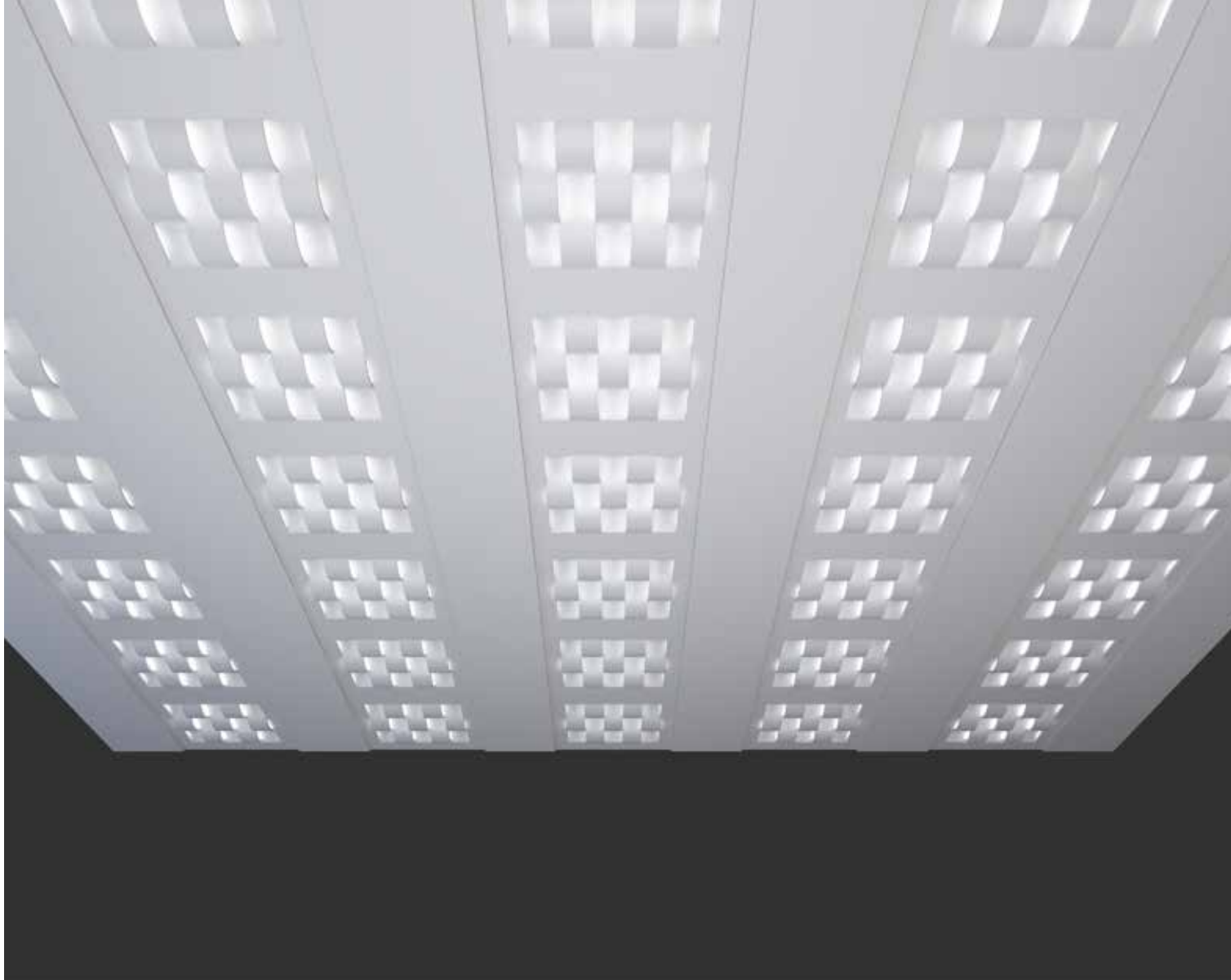

Art. 1843

AURORA

Un pannello che permette di arricchire un controsoffitto in cartongesso in modo originale. È costituito da onde sfalsate, attraverso le quali, è possibile il passaggio della luce e dell'aria tra una cresta e l'altra, per condizionare il vostro ambiente.

A panel that allows decorating a drywall false ceiling in an original way. It is composed of staggered waves, and the light and air that pass through them decorate your rooms.

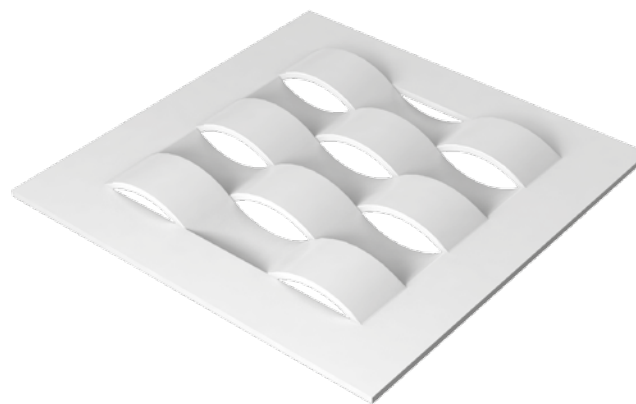
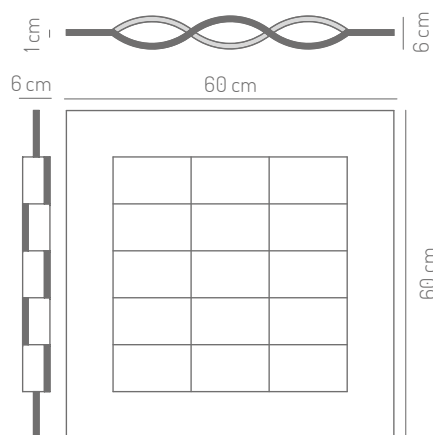

BOISERIE

BOISERIE

Questo tipo di prodotto generalmente classico viene presentato in chiave più moderna proponendo modanature lisce e pulite. Vengono indicate soluzioni diverse sia per estetica che per tecnica. Abbiamo realizzato più proposte che vanno da uno a quattro livelli, che permettono al progettista di individuare la soluzione più opportuna per le proprie esigenze. Inoltre l'effetto dei livelli può essere valorizzato dalla decorazione.

This type of product, usually classic, is presented in modern version proposing smooth and clean forms. Different aesthetic and technical solutions are indicated. We have realised different proposals ranging from one to four levels, which allow the designer to identify the most appropriate solution to one's own needs. In addition, the effect of the levels can be valorised by decoration.



Boiserie a 4 livelli



Composizione con: Battiscopa Art. 2356 - Fascia Art. 2405 - Marcapiano Art. 2344 - Cornice Art. 2276

Boiserie a 3 livelli

2 cm



3 cm

21 cm

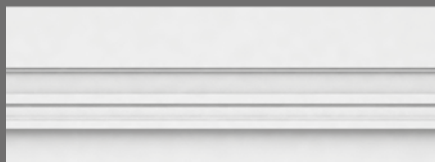

Art. 2406
Fascia realizzata con cornice
Art. 2412 incorporata



Composizione con: Battiscopa Art. 2265 - Fascia Art. 2406 - Pannelli Art. 1819 e 1820
Marcapiano Art. 2163 - Luce diffusa Art. 170

1,25 cm



25 cm

90 cm



Art. 1819 cm 90x90
con cornice Art. 2412 incorporata

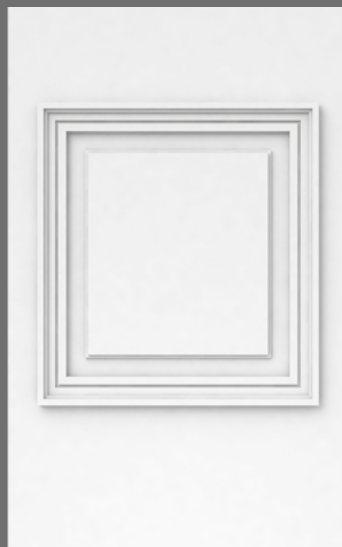

Art. 1820 cm 55x90
con cornice Art. 2412 incorporata

Boiserie a 2 livelli



Composizione con: Battiscopa Art. 2394 - Pannelli Art. 1821e1822 - Marcapiano Art. 920 - Sguscia Art. 2385

1,25 cm



Art. 1821 cm 60x95



Art. 1822 cm 35x95

Boiserie unico livello



Composizione con: Battiscopa Art. 2395 - Pannello Art.1823 - Marcapiano Art.2389 - Cornice Art. 2253

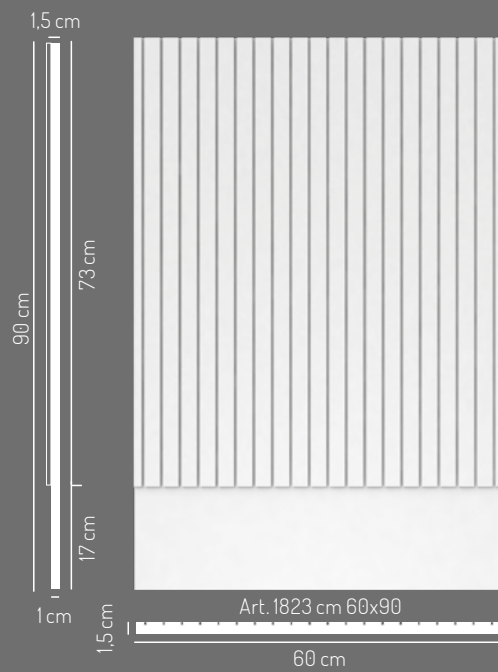

Boiserie libera



Art. 2407 fascia



Art. 1827 24x24 cm



Art. 1828 16x16 cm



Composizione con: Battiscopa Art. 2396 - Fascia Art. 2407 - Angolo Art. 1828 - Luce diffusa Art. 170

1,25 cm



99 cm

23 cm



Art. 1824 cm 70x99



Art. 1825 cm 50x99



Art. 1826 cm 40x99

Boiserie libera

2,5 cm



7,5 cm

Art. 2345

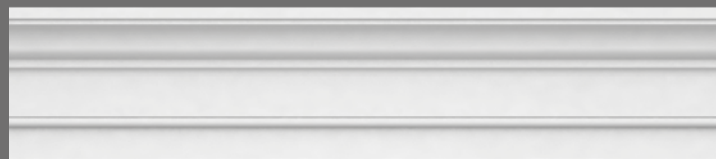

Art. 2262



Art. 1770 angolo 27x27



Art. 1769 angolo 30x30



Art. 1772 13 x h 34 cm



Art. 1771 11 x h 34 cm

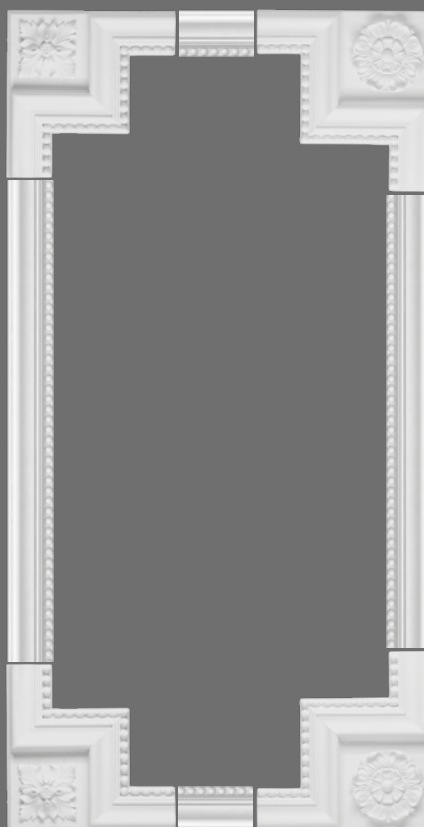

Art. 2345

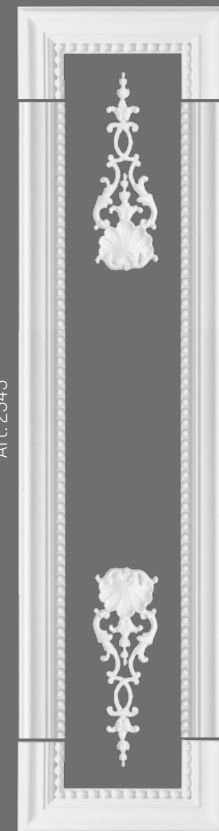

Art. 2345



Art. 2344

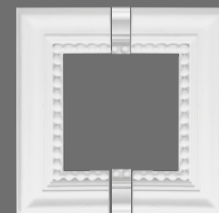

Composizione con: Battiscopa Art. 2356 - Cornice Art. 2345 - Terminale Art. 1772
 Marcapiano Art. 2344 - Angolo Art. 1769 - Angolo Art. 1770
 Fregio Art. 1771 - Cornice Art. 2262

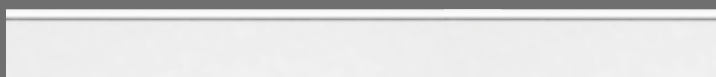

Art. 2356

Boiserie libera

2,2 cm

7 cm



Art. 2342



Art. 1768 angolo 20x20



Art. 1767 angolo 16x16



Art. 2253

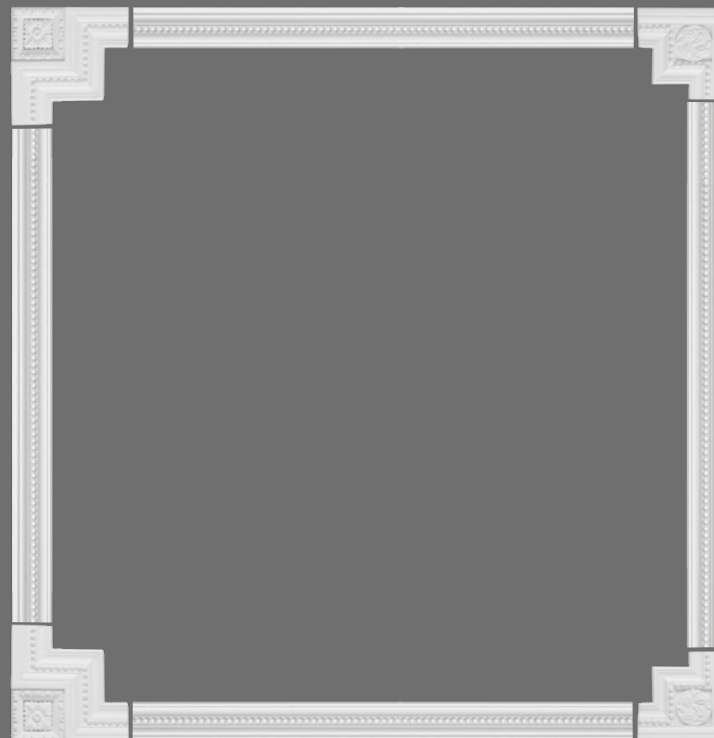

Art. 2342



Composizione con: Battiscopa Art. 2403 - Cornice Art. 2342 - Marcapiano Art. 648/B
Angolo Art. 1767 - Angolo Art. 1768 - Cornice Art. 2253

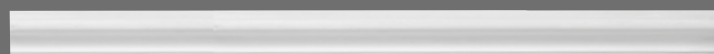

Art. 648/B

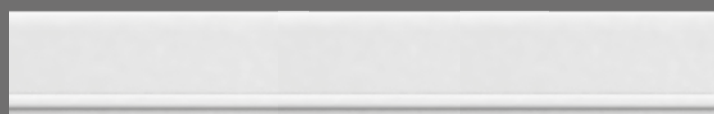

Art. 2403

Composizione con:
Battiscopa Art. 2265
Cornice boiserie Art. 2412
Marcapiano Art. 2388
Tozzetto Art. 1792
Cornice per finestre Art. 2381
Zoccolo porte Art. 1794
Cornice porta Art. 2404
Controsoffitto Alveare Art. 1842

Composition with:
Skirting boards Art. 2265
Boiserie frame Art. 2412
String-course frame Art. 2388
Tozzetto tiles Art. 1792
Window frame Art. 2381
Door base Art. 1794
Door frame Art. 2404
False ceiling Alveare Art. 1842

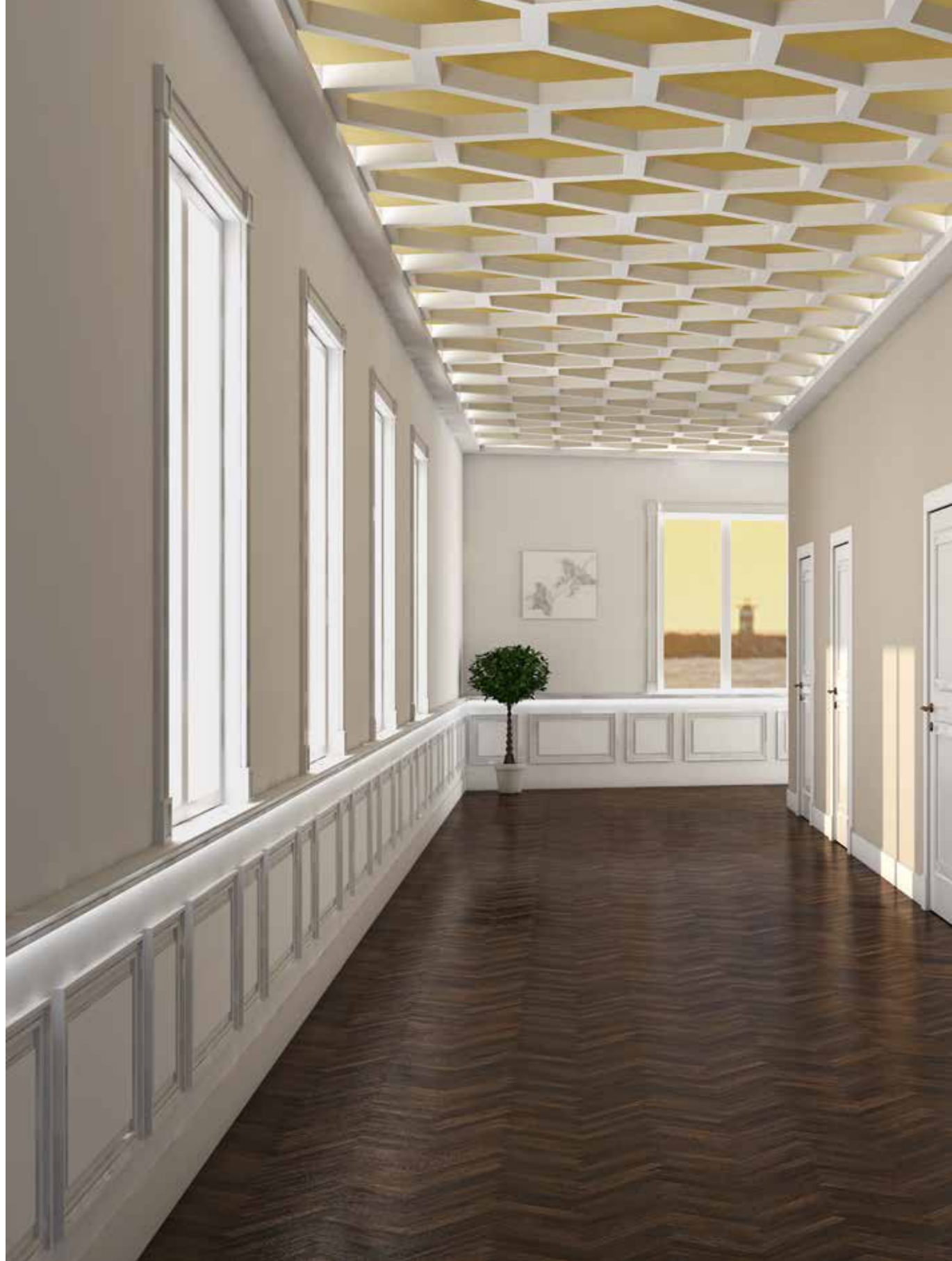



Boiserie libera



Esempio montaggio con: Battiscopa Art. 2396 - Cornice boiserie Art. 126
Angolo boiserie Art. 1755 - Marcapiano Art. 2359 - Cornice soffitto Art. 2393

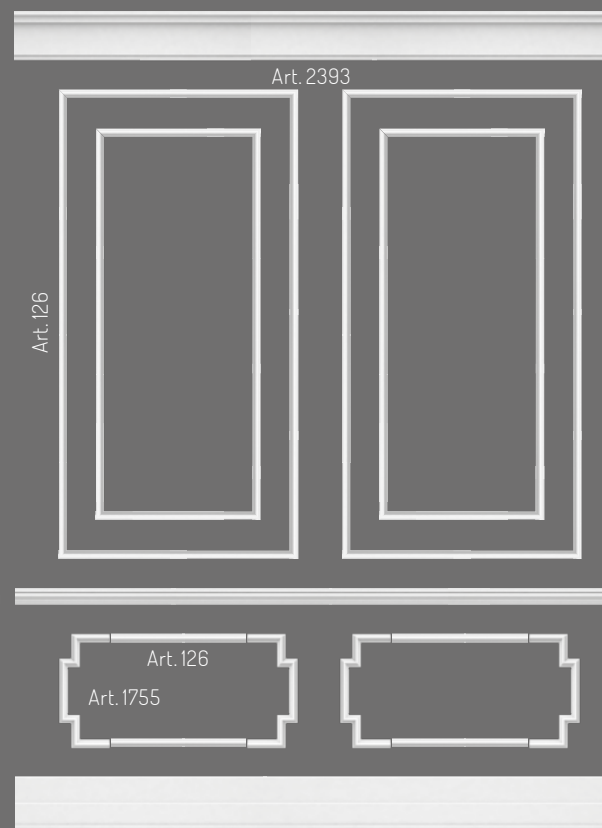

Boiserie libera

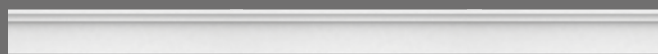
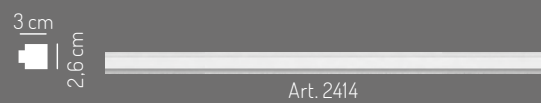

Art. 2393

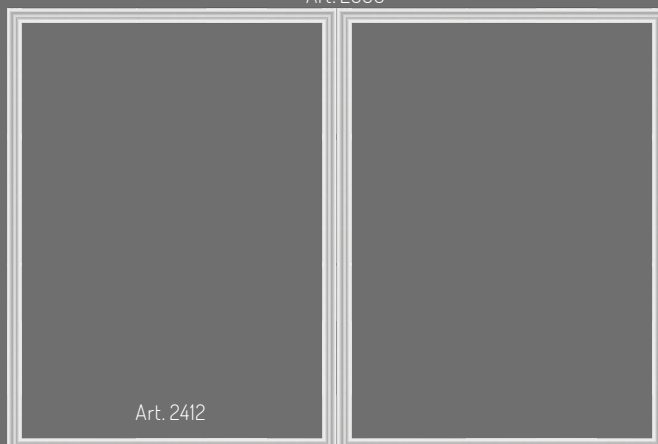

Art. 2414

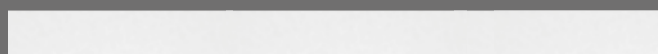

Art. 2265



Esempio montaggio con : Battiscopa Art. 2265 - Cornice boiserie Art. 2412
Marcapiano Art. 2414 - Cornice soffitto Art. 2393

Boiserie libera

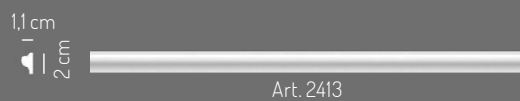

Art. 2262

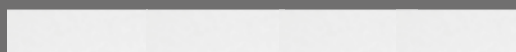
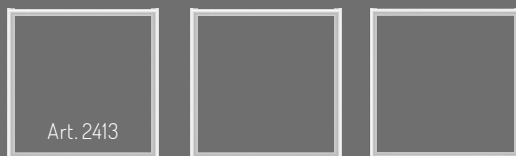
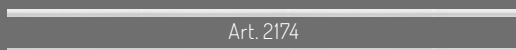
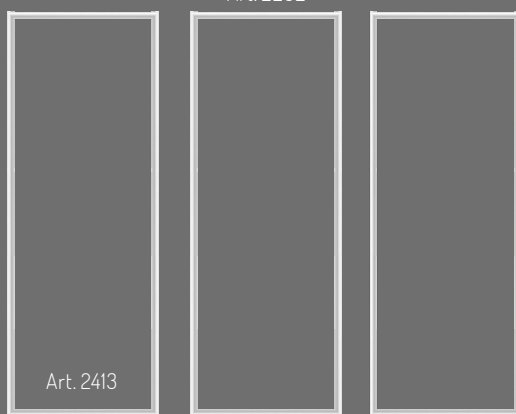

Art. 2265



Esempio montaggio con: Battiscopa Art. 2265 - Cornice boiserie Art. 2413
Marcapiano Art. 2174 - Cornice soffitto Art. 2262

Boiserie libera

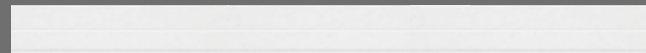
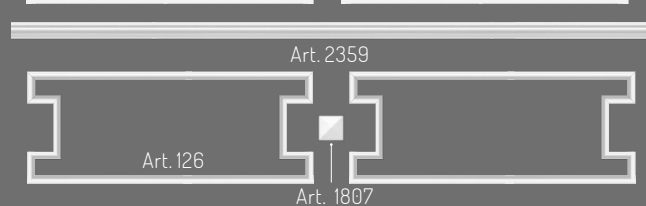
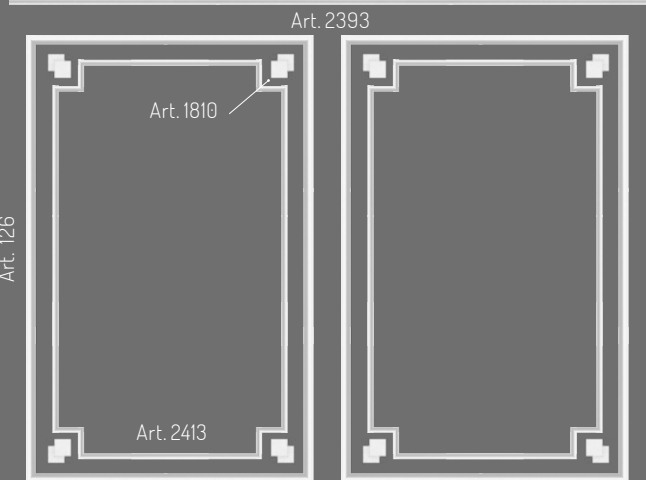
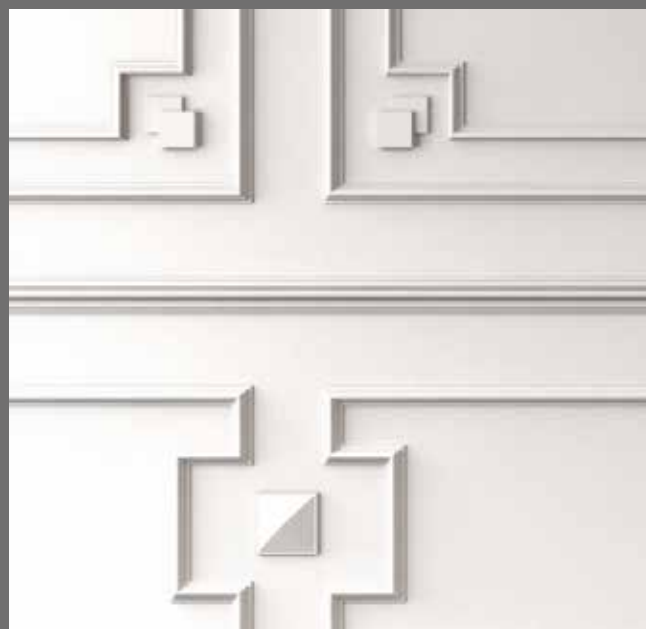
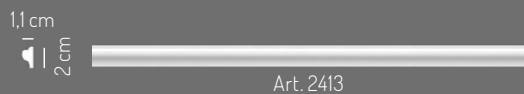

Esempio montaggio con: Battiscopa Art. 2396 - Cornice boiserie Art. 126
Tozzetto boiserie Art. 1807 - Marcapiano Art. 2359 - Cornice boiserie interna Art. 2413
Tozzetto boiserie Art. 1810 - Cornice soffitto Art. 2393

QUADRI DECORATIVI *DECORATIVE TILES*

Mantenendo sempre il nostro obiettivo di fare arredamento con elementi tridimensionali, che permettono di ottenere giochi di luci e ombre, si propongono in questo capitolo i quadri. Sono elementi dalle dimensioni più contenute che consentono di decorare qualunque vostro spazio. Proponendo disegni più vari, con movimenti plastici o netti, abbiamo ricercato originalità nella semplicità. Nasce così l'ispirazione al mondo naturale più dinamico e alla geometria, talvolta fluida talvolta severa.

Trying to preserve our objective to décor with tridimensional elements that allow obtaining plays of light and shade, in this chapter we propose decorative tiles. They are elements with smaller dimensions that allow decorating any space. Proposing the most varied patterns, with plastic or net movements, we searched for originality in simplicity. Thus, the inspiration to a more dynamic natural world and geometry, sometimes fluid and sometimes severe.





Art. 1835

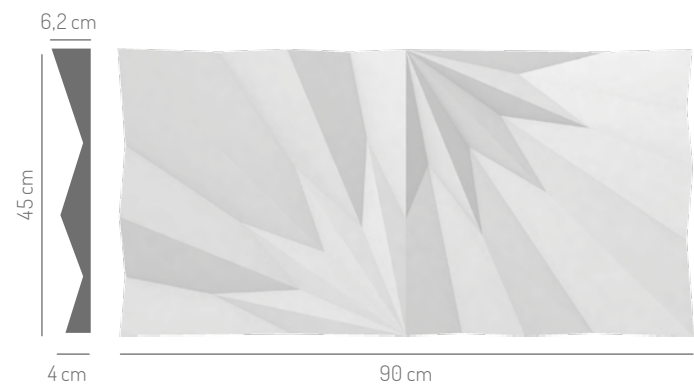



Art. 1836 - 1837

4 cm

20 cm



Art. 1836
105 x 20 x p 4 cm

4 cm

74 cm



Art. 1837
35 x 74 x p 4 cm



Art. 1838 - 1839

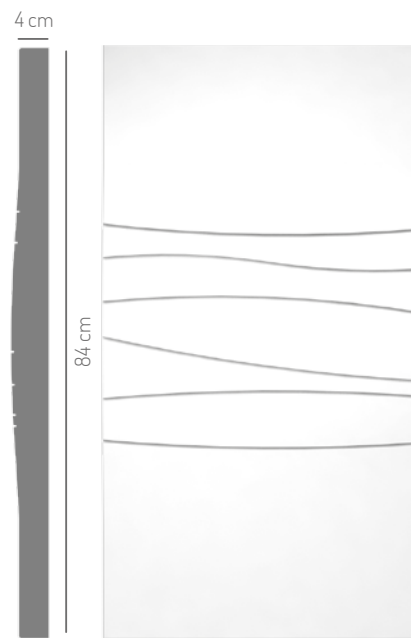

Art. 1838
45 x 84 x p 4 cm

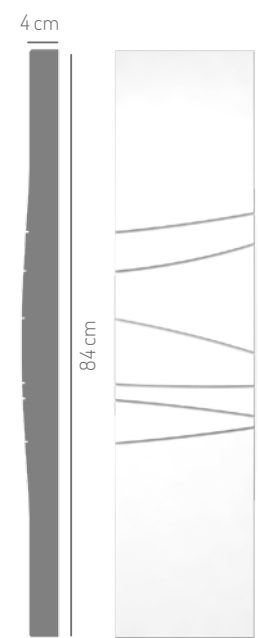

Art. 1839
20 x 84 x p 4 cm

CAMINETTI IN GESSO CERAMICO

CERAMIC PLASTER FIREPLACES

I Caminetti da rivestimento caratterizzano in modo particolare ed esclusivo ogni ambiente. Per la realizzazione di questi manufatti vengono usati dei gessi ceramici selezionati e ultrasensibili, miscelati con microfibre e fibre vegetali. Alcuni modelli hanno in abbinamento dei quadri decorativi con lo stesso motivo dei caminetti, per offrire un'ulteriore opportunità di arredamento.

Decorative fireplaces are the exclusive characteristic of every room. For the realisation of these elements selected and ultra-resistant ceramic plasters are used, mixed with microfibres and vegetal fibres. Some models are matched with decorative tiles with the same motif of the fireplace, to offer an extra decoration.



Art. FS 18 Caminetto

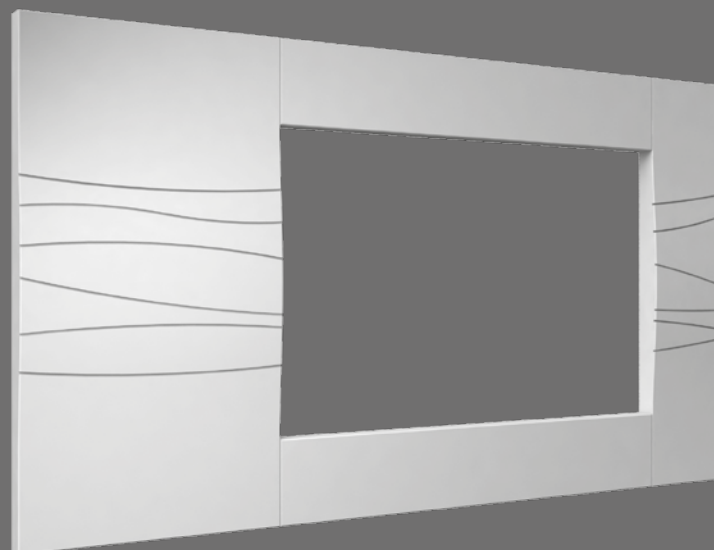
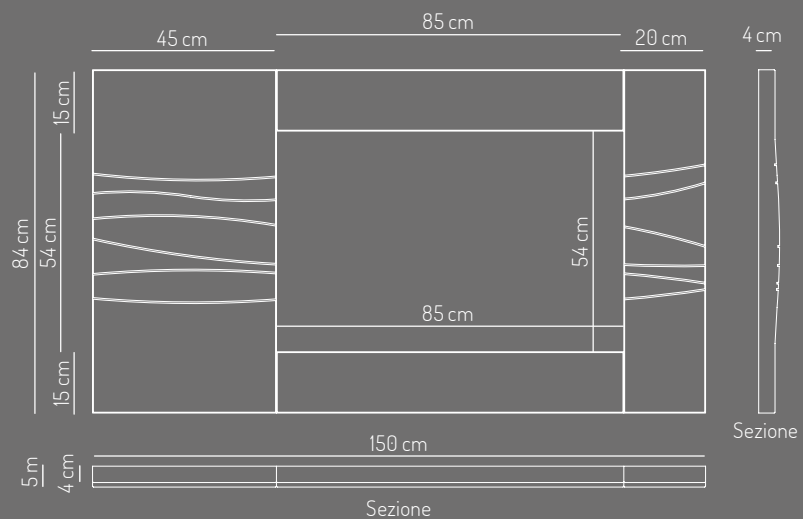

Art. FS 18 Caminetto composto da 4 pezzi

Art. FS19 Caminetto

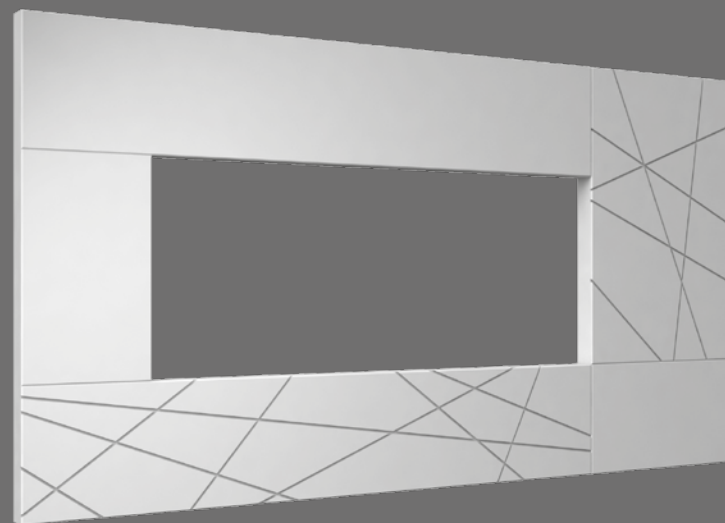
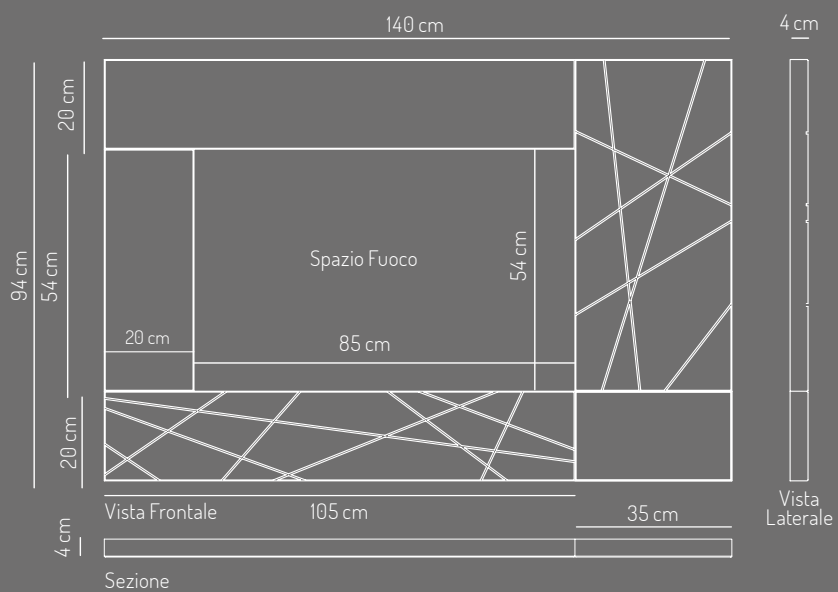

Art. FS19 Caminetto composto da 5 pezzi

Art. FS 20 Caminetto

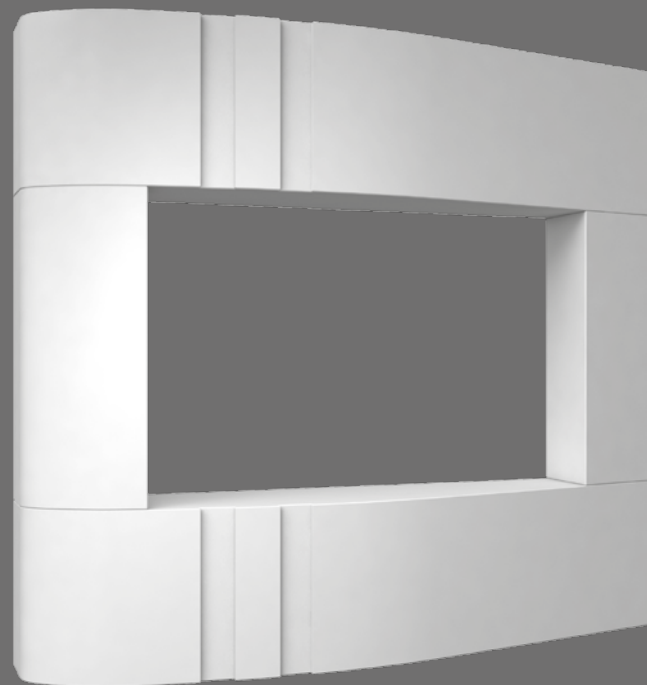
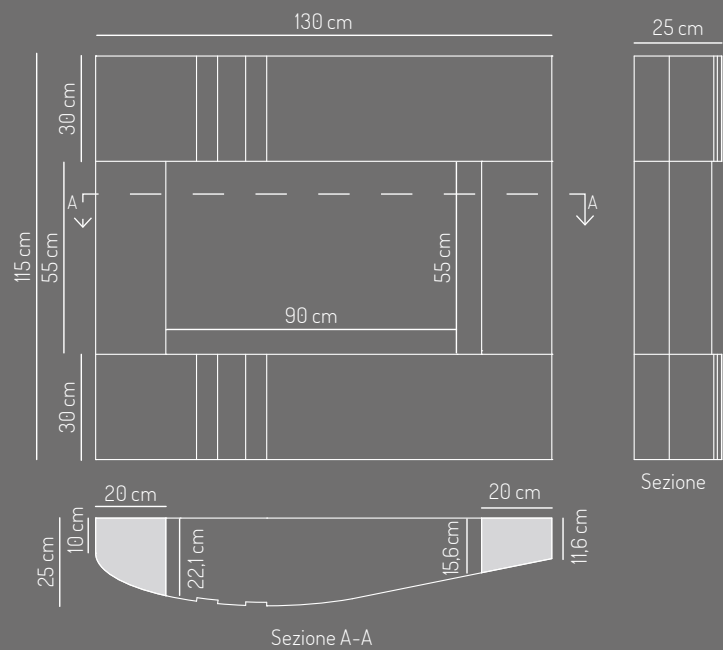

Art. FS 20 Caminetto composto da 4 pezzi

ILLUMINAZIONE

LIGHTING

Proponiamo un nuovo assortimento di profili che desiderano soddisfare le piu' svariate esigenze per illuminare gli ambienti. Dalle luci diffuse tradizionali, con l'applicazione del semplice neon all'interno, si passa ad innovativi profili che prevedono l'inserimento della striscia LED, posizionata su dissipatore in alluminio o direttamente su gesso con strisce LED idonee. Alcuni profili sono polivalenti e possono essere posati sia sulla parete che sul soffitto e possono essere utilizzati come marcapiani e battiscopa con la propria luce di cortesia. Di particolare rilievo è il profilo a scomparsa da incassare nel cartongesso. Con i suoi accessori è possibile posarlo senza interruzioni sia a soffitto che a parete.

We propose a new range of profiles in order to meet all kinds of needs and illuminate rooms. From traditional lighting coves, with the application of neon inside, we pass to innovative profiles that include the insertion of the LED strip, positioned on aluminium heat sink or directly on the plaster with suitable LED strips. Some profiles are multi-purpose and can be positioned both on wall and ceiling, and can be used as string-course frames and skirting boards with their own courtesy light. Noteworthy is the recessed profile built-in the drywall. Thanks to its accessories it is possible to position it without interruptions both on the wall and ceiling.



Colonna

Design Architetto Francesca Abbruzzese

Semicolonna



Art. 1844

Art. 2411

Art. 1840

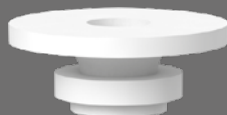

Art. 1844
 Ø Superiore 45 cm
 Ø Inferiore 26,5 cm
 H 15 cm
 H battente 3 cm



Art. 2057 anima liscia
 Ø Esterno 16 cm

Art. 2411
 Ø Esterno 27 cm
 H tot. 230 cm

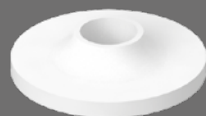

Art. 1840
 Ø Inferiore 45 cm
 Ø Superiore 20 cm
 H 10 cm



Art. 1844 a metà

Art. 2410

Art. 1840 a metà



Art. 1844 a metà
 Ø Superiore 45 cm
 Ø Inferiore 26,5 cm
 H 15 cm
 H battente 3 cm

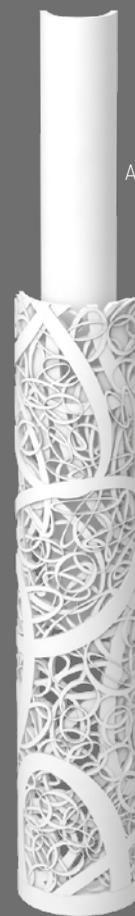

Art. 2060 anima liscia
 Ø Esterno 16 cm

Art. 2410
 Ø Esterno 27 cm
 H tot. 230 cm



Art. 1840 a metà
 Ø Inferiore 45 cm
 Ø Superiore 20 cm
 H 10 cm

L'inserimento della semicolonna o della colonna liscia all'interno è a discrezione del cliente a seconda dell'effetto luce desiderato.
 The insertion of the half-column or smooth column is on request of the customer according to the desired light effect.

Composizione con:
Battiscopa Art. 2390
Base Art. 1840
Colonna Art. 2411
Capitello Art. 1844
Controparete Eclisse Art. 1841
Cornice per finestre Art. 2381
Tozzetto Art. 1792
Sguscio Art. 2383

Composition with:
Skirting boards Art. 2390
Base Art. 1840
Column Art. 2411
Capital Art. 1844
Eclisse false wall Art. 1841
Window frame Art. 2381
Tozzetto tiles Art. 1792
Coving element Art. 2383





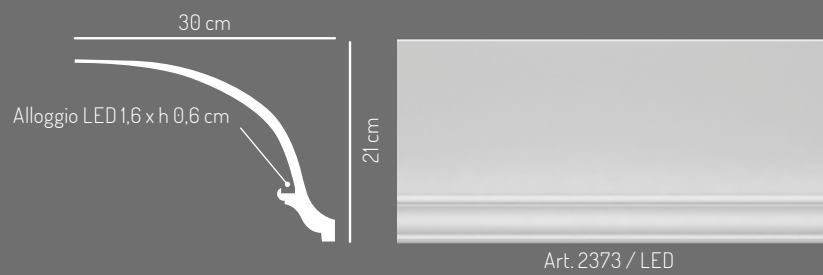

Esempio montaggio con Art. 2373 / LED

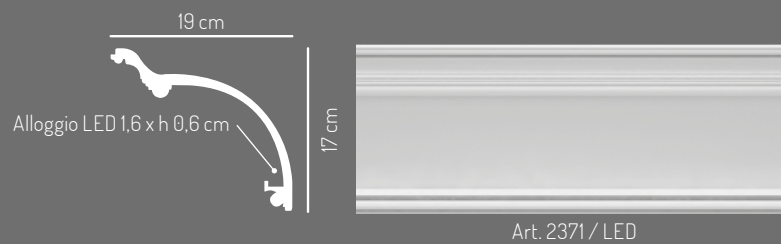

Esempio montaggio con Art. 2371 / LED

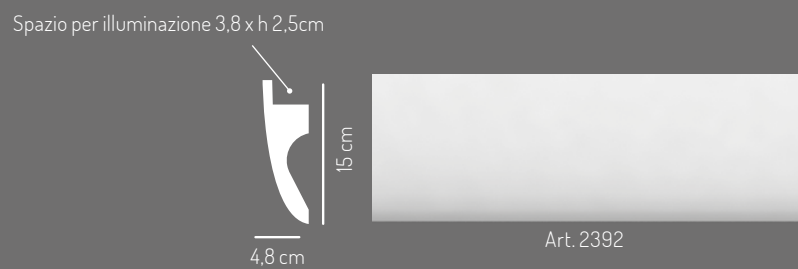

Esempio montaggio con Art. 2392

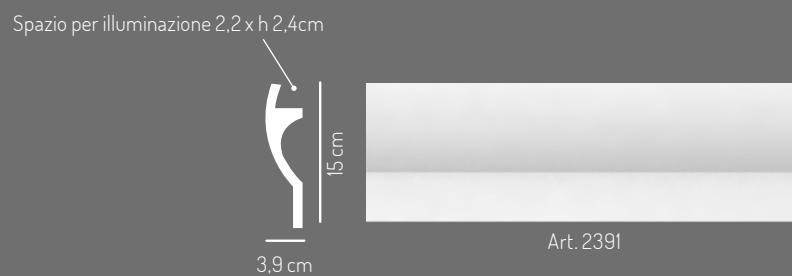

Esempio montaggio con Art. 2391

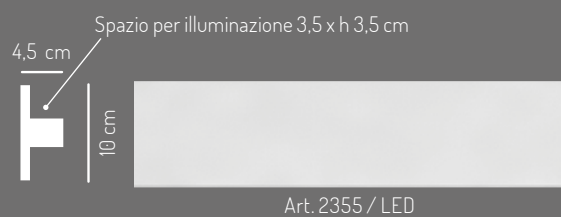
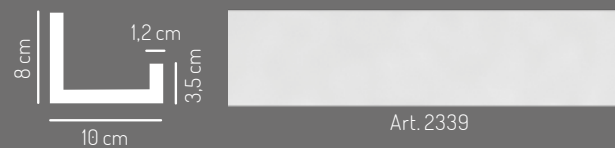
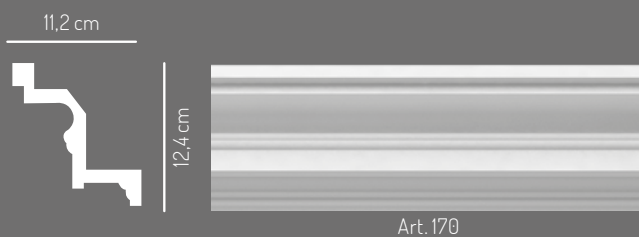



Alloggio LED
L 1,3 cm

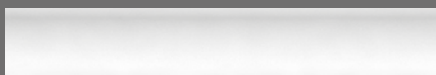

Art. 2397 Cornice levangolo



Esempio montaggio con Art. 2397 con LED



Alloggio LED
L 1 cm



Art. 2398 Cornice levangolo



Esempio montaggio con Art. 2398 con LED

2,7 cm



11 cm



Art. 2415 Cornice marcapiano

Alloggio LED 1,8 x h 0,5 cm



Esempio montaggio con Art. 2415 con LED

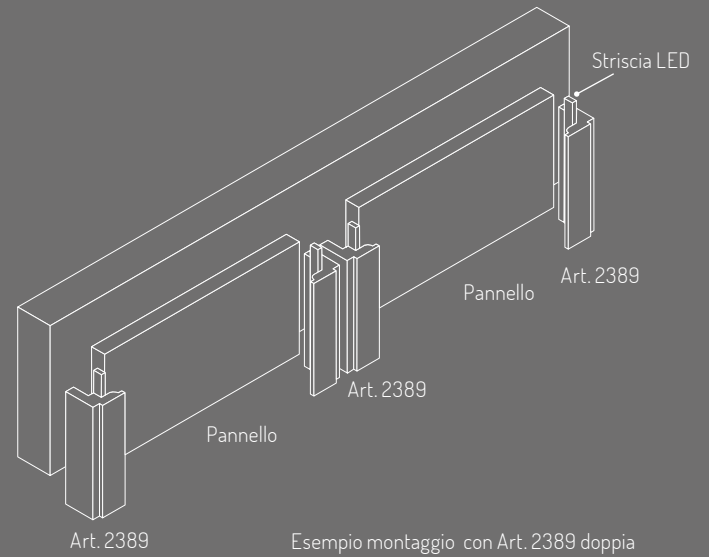
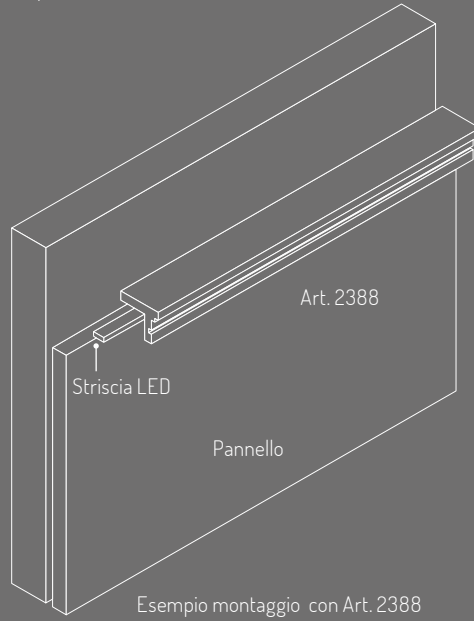
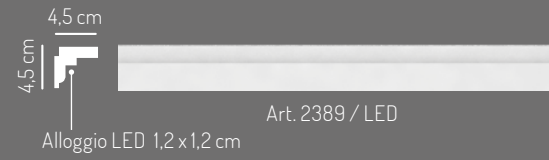

Esempio di realizzazione con Art. 2388 nel nostro show room



Esempio di realizzazione con Art. 2389 / LED nel nostro show room

Composizione con:
Pannello 4Tweed
Pannello Tweed
Cornice da incasso Art. 1799
Angolo Art. 1801
Angolo Art. 1802
Quarto di cerchio Art. 1803
Semicerchio Art. 1804

Composition with:
4Tweed Panel
Tweed Panel
Built-in frame Art. 1799
Corner Art. 1801
Corner Art. 1802
Quarter of a circle Art. 1803
Semicircles Art. 1804





5th AVENUE

Luci da incasso parete / soffitto

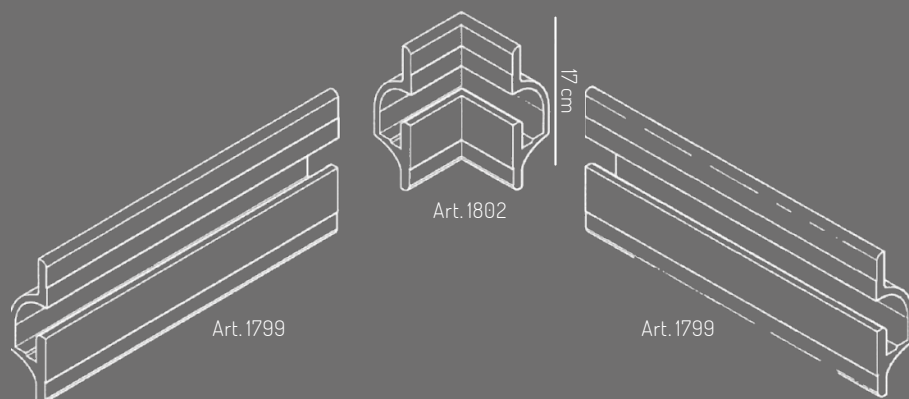

Composizione Art. 1802 - Art. 1799

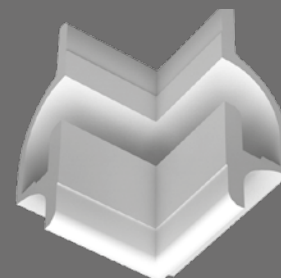

Art. 1802
Parte elettrica non inclusa

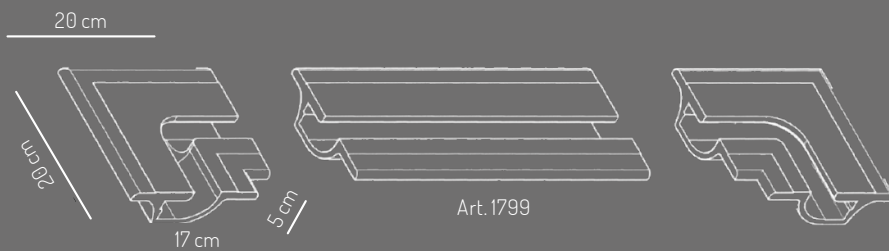

Composizione Art. 1800 - Art. 1799

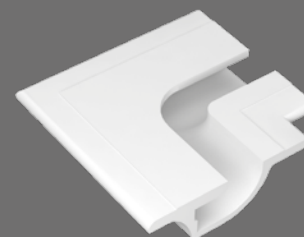

Art. 1800
Parte elettrica non inclusa

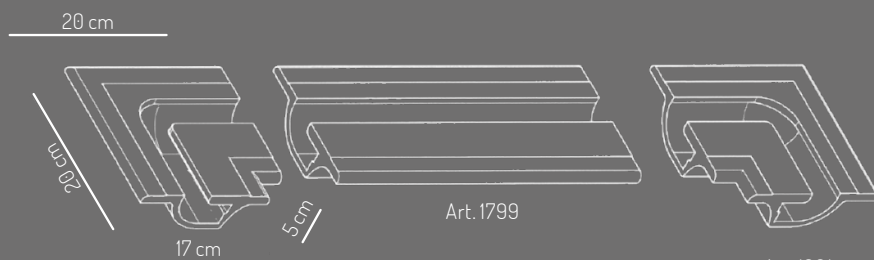

Composizione Art. 1801 - Art. 1799

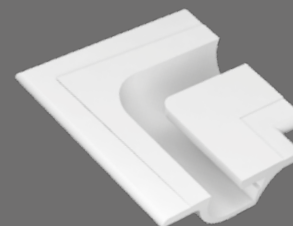

Art. 1801
Parte elettrica non inclusa



Art. 1799 Parte elettrica non inclusa
lunghezza 1 mt.

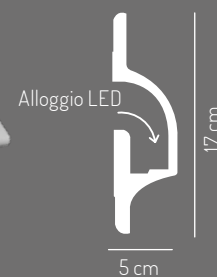

Luci da incasso parete / soffitto

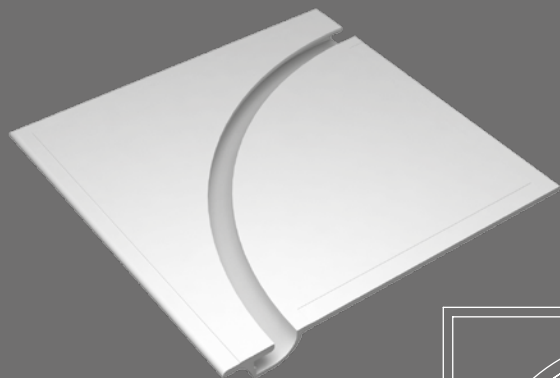

Art. 1803 Parte elettrica non inclusa

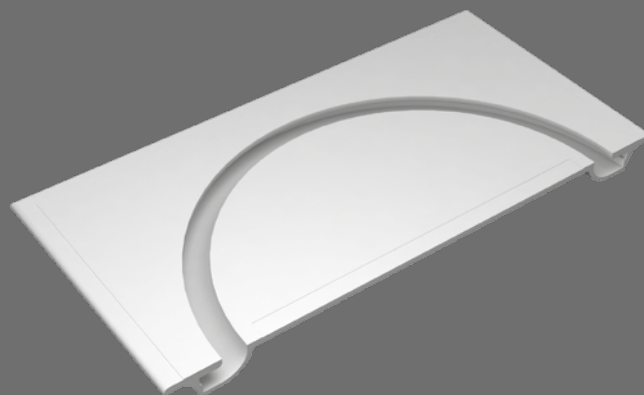
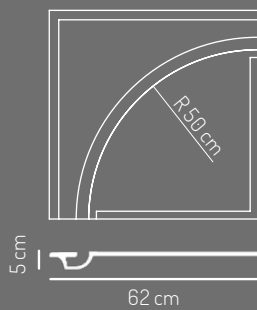

Art. 1804 Parte elettrica non inclusa

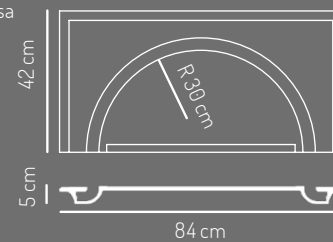

Realizzato con Pannello Tweed - Cornice da incasso Art. 1799 - Accessori Art. 1802, 1803 e 1804



5,5 cm

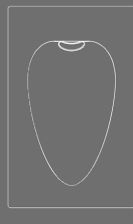

23 cm

14,5 cm

Art. 1796
corredata di portalampada - 220V

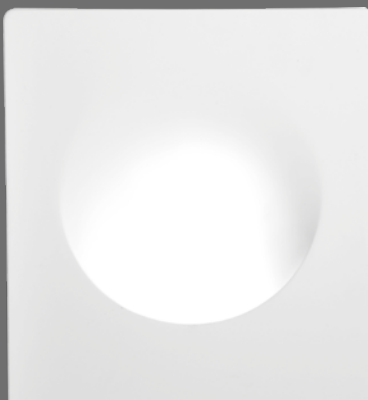

5,8 cm

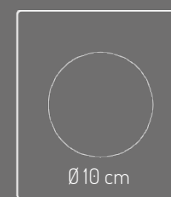

25 cm

20,5 cm

Art. 1797
corredata di portalampada - 220V



7,5 cm



35 cm

29 cm

Art. 1798
corredata di portalampada - 220V



SGUSCI

COVING ELEMENTS

Con questo tipo di profili dalle svariate forme, possiamo raccordare la parete al soffitto conferendo all'ambiente una continuità decorativa, che sembra ampliare i diversi volumi. Di particolare rilievo sono i profili che si estendono con maggiore aggetto nel soffitto, grazie alle sezioni con curvature ellittiche, nettamente moderne rispetto alle classiche circolari.

With this type of profiles of various forms, we can match the walls with the ceiling giving the room a decorative continuity that seems to widen the different volumes. Noteworthy are the profiles overhanging from the ceiling, thanks to the sections with elliptical curvatures that are clearly more modern compared to the classic circular ones.



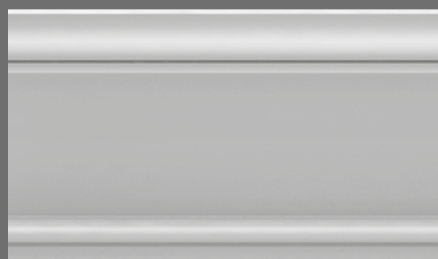

Art. 2367

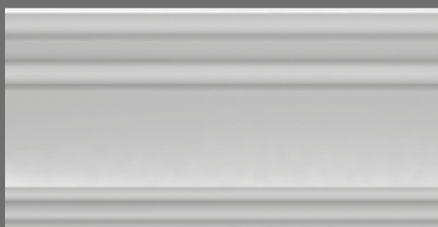
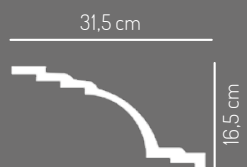

Art. 2383

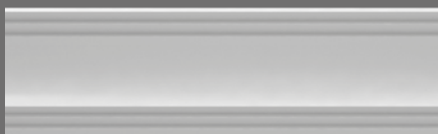
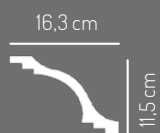

Art. 2384

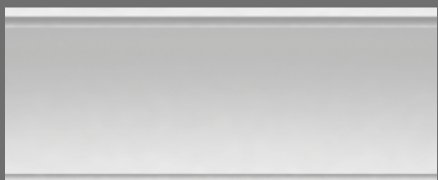
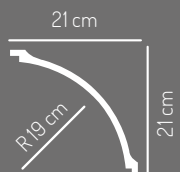

Art. 2013

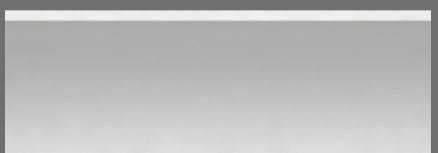

Art. 2064

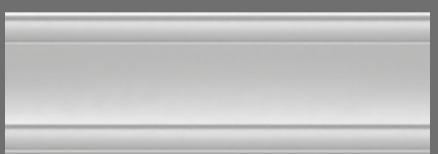

Art. 2354



Esempio montaggio sgusci con Art. 2367



Esempio montaggio sgusci con Art. 2354



Art. 2385



Art. 30L

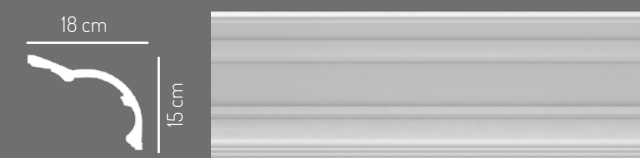

Art. 2338

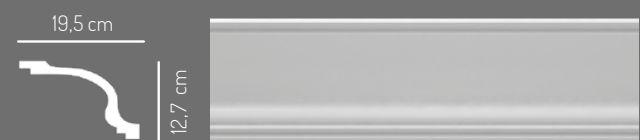

Art. 2182

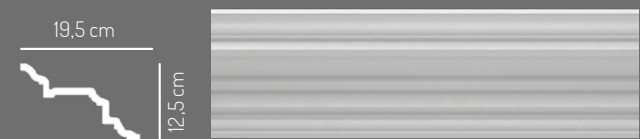

Art. 2368

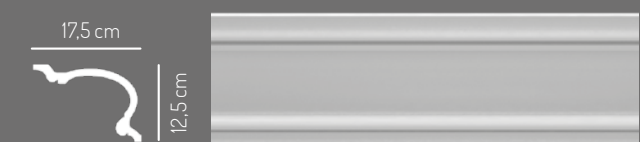

Art. 2366



Esempio di realizzazione di veletta con Art. 2338



Art. 917

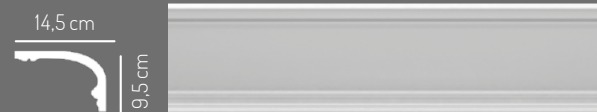

Art. 53A



Art. 171



Art. 2257



Esempio di realizzazione di cassettonato con Art. 53/A



Art. 2232



Realizzato con sguscio Art. 2383

CORNICI FRAMES

Nella logica di proporre un design nuovo sono state disegnate cornici per lo più lisce e pulite da proporre come liste da porta, corredate dei propri zoccoli, come cornici parete – soffitto o come semplici marcapiano per boiserie. Originale è il richiamo alla texture del legno; un effetto rigato e irregolare che richiama i materiali classici proposti anche nei pannelli murali.

Our new design includes also smooth and clean frames to be proposed as door strips, together with their own bases, such as wall – ceiling frames or simple string-course frames for boiserie. Original is the recall to wood texture; a striped and irregular effect recalling the classic materials proposed also in the wall panels.



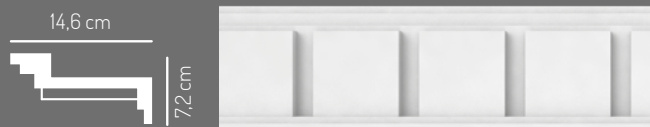

Art. 2399

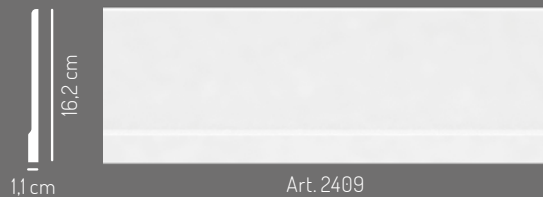

Art. 2409

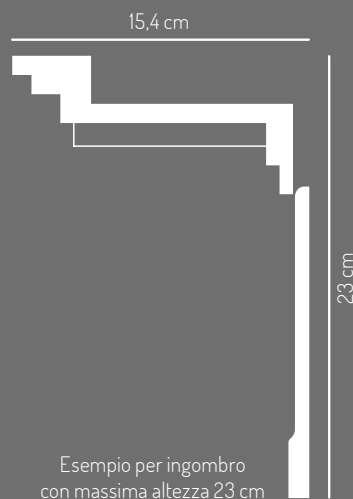

Esempio per ingombro
con massima altezza 23 cm

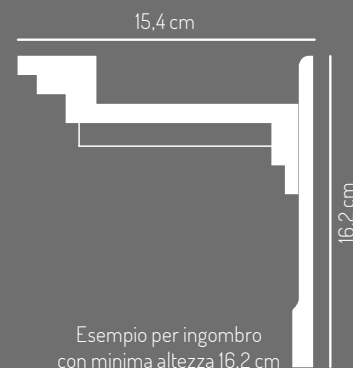

Esempio per ingombro
con minima altezza 16,2 cm



Esempio montaggio con Art. 2399 e Art. 2409



Art. 2262

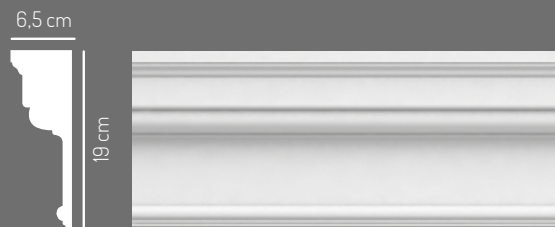

Art. 2253



Art. 2276



Art. 2343



Art. 920



Art. 191

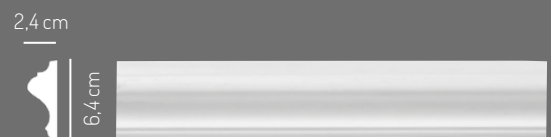

Art. 648 / B



Art. 2163



Art. 2025



Art. 2344



Art. 2359



Art. 2360

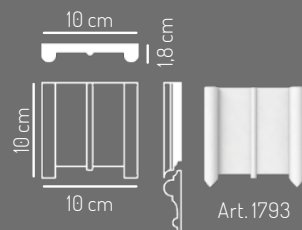
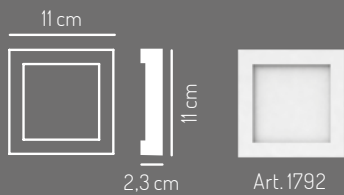
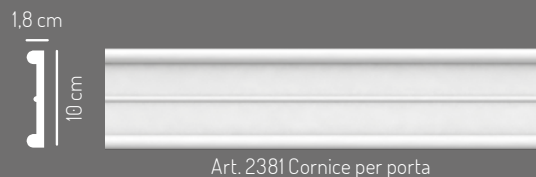

Terminale per Art. 2163

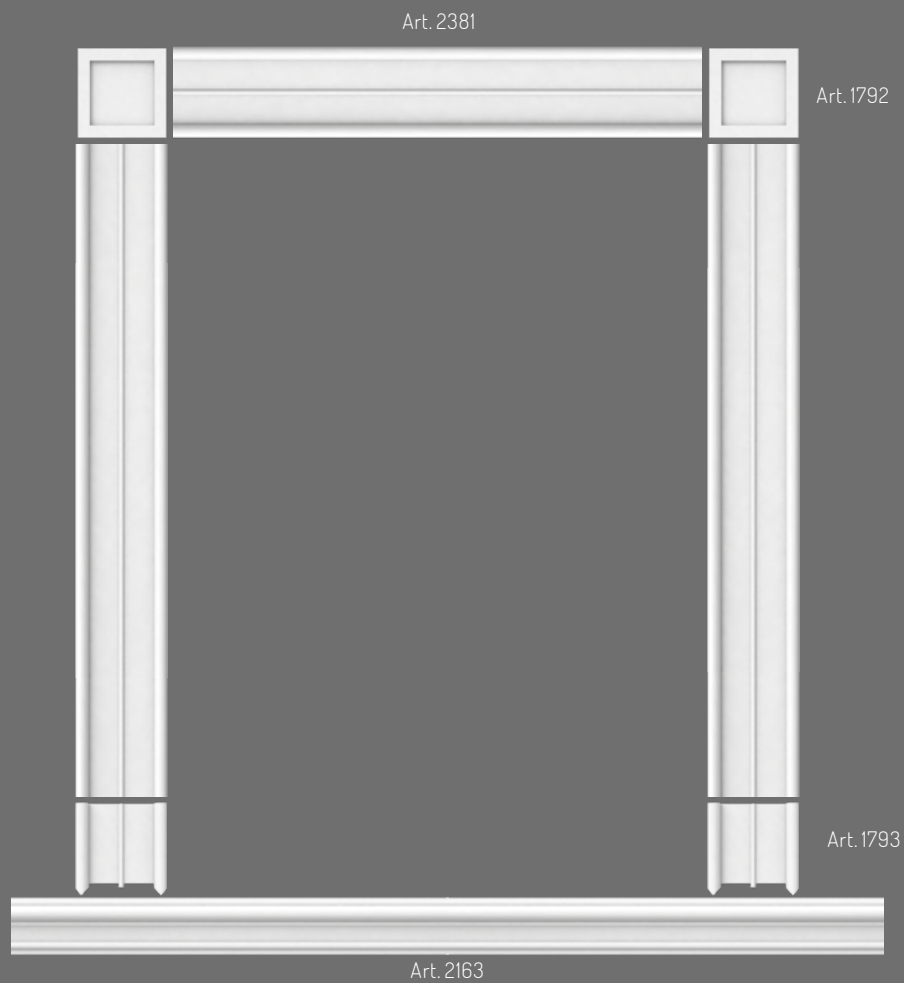
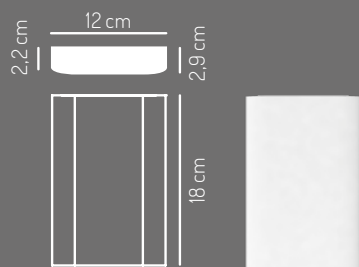

Esempio di realizzazione con Marcapiano Art. 2163 - Tozzetto Art. 1792 - Cornice Art. 2381

Composizione con:
Battiscopa Art. 2356
Zoccolo porta
Art. 1830 dx e 1830 sx
Cornice per porta Art. 2387
Pannello Scirocco
(adiacente all'arco)
Pannello Grecale (dentro la nicchia)
Fascia lavorata Jugla
Cornice marcapiano Art. 2388
Trave Ulmo

Composition with:
Skirting boards Art. 2356
Door base
Art. 1830 right and 1830 left
Door frame Art. 2387
Scirocco Panel (next to the arch)
Grecale Panel (inside the niche)
Jugla decorated strip
String-course frame Art. 2388
Ulmo beam





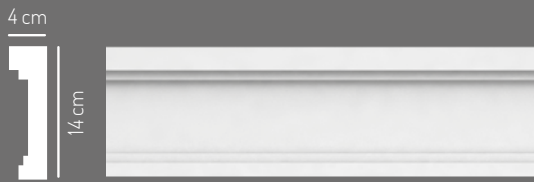

Art. 2386 Cornice per porta

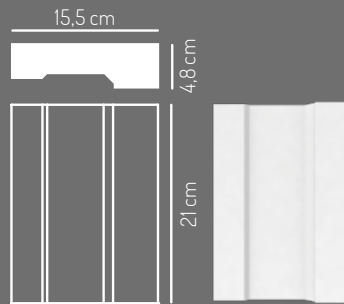

Art. 1829 Zoccolo per Art. 2386



Esempio di realizzazione con Art. 2386 nel nostro show room



Art. 2387 Cornice per porta
con finitura tipo legno

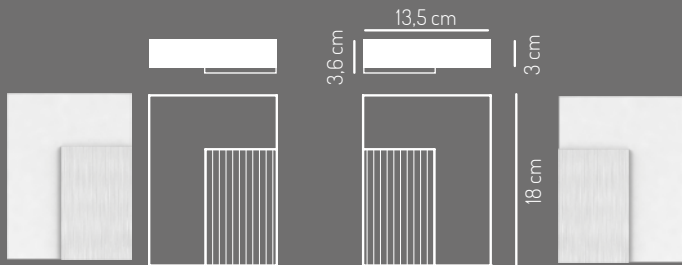

Art. 1830 / S

Art. 1830 / D

Art. 1830 Zoccolo per Art. 2387



Esempio di realizzazione con Art. 2387 nel nostro show room



Art. 2404 Cornice per porta



Art. 2393 Cornice per porta

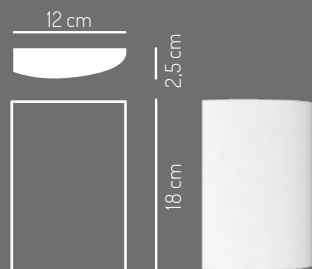

Art. 1831 Zoccolo per Art. 2404

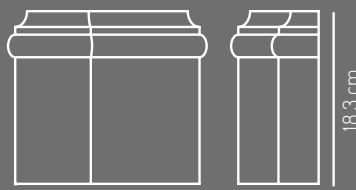
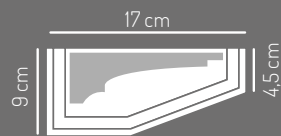

19,5 cm

8,3 cm

18,3 cm



Art. 1818 / S



Art. 1818 / D

Art. 1818 Zoccolo per Art. 2393



Composizione con battiscopa Art. 2402 - zoccolo Art. 1818 / S - cornice per porta Art. 2393

BATTISCOPA SKIRTING BOARDS

La nuova linea dei battiscopa è forse quella che prende le maggiori distanze dai nostri classici. Non più gole dritte o becco di civetta ma spigoli più evidenti. Anche in questi articoli si richiama la linea, la quale permette di marcare in modo netto un elemento essenziale della parete come è il battiscopa. Alcuni articoli permettono inoltre l'eventuale predisposizione della striscia LED. L'altezza di alcuni è stata pensata in abbinamento agli zoccoli delle liste da porta presenti nel nostro catalogo.

The Skirting boards new line is maybe the one that distances more from our classics. More evident outside corners instead of straight or rounded edges. Line is recalled also in these articles, allowing marking clearly an essential element of the wall such as the skirting board. In addition, some articles allow prearranging LED strip. The height of some of them matches the door strips bases included in our catalogue.



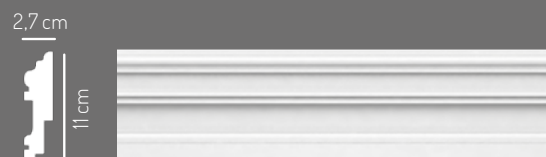

Art. 2401



Art. 2400

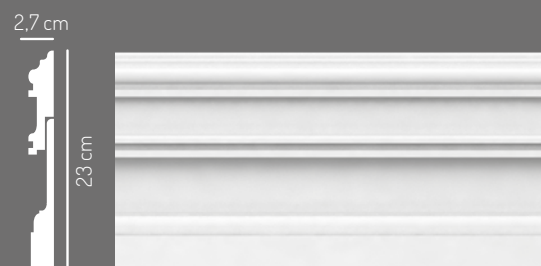

*Esempio per ingombro con minima altezza, 23 cm

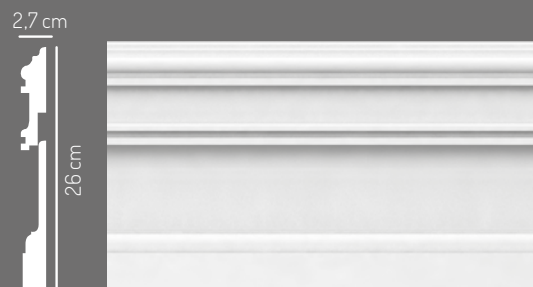

*Esempio per ingombro con massima altezza, 26 cm

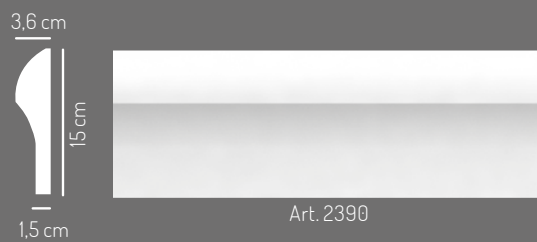

Art. 2390



* Esempio di montaggio con Art. 2400 e Art. 2401



Esempio montaggio con Art. 2390

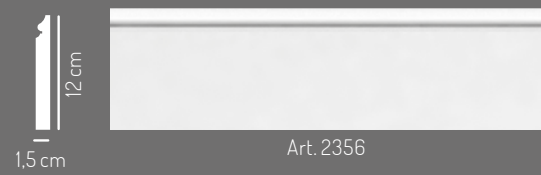
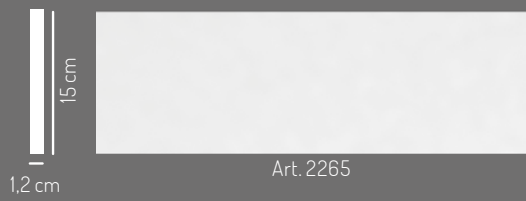
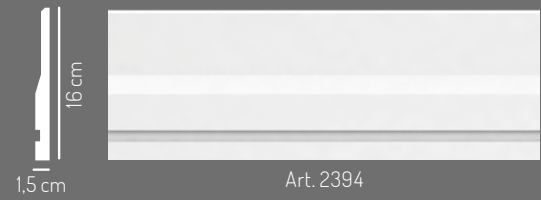
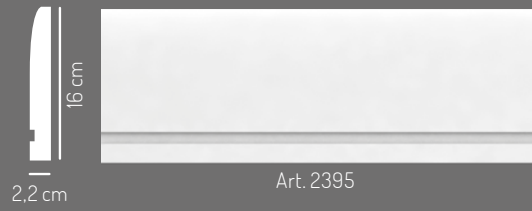
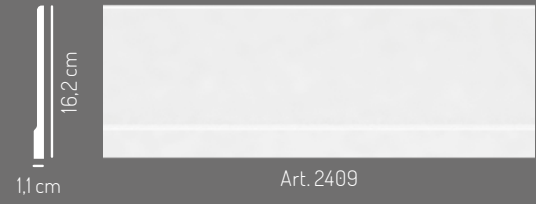
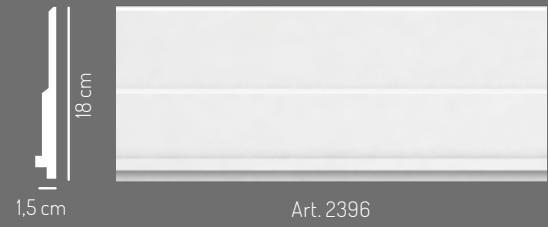
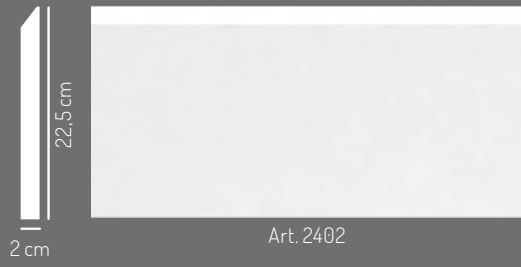

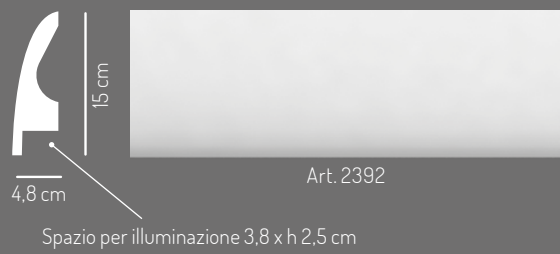

Esempio montaggio con Art. 2392

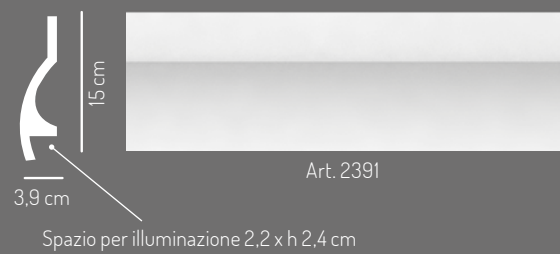

Esempio montaggio con Art. 2391



toscanstucchi

ARTE IN OPERA

CONTEMPORARY

A.S.F. enterprise s.r.l.

Loc. Pian dell'Olmino / Santa Giulia, 57/58

53034 Colle di Val d'Elsa (SI) Italy

Tel. +39.0577.929224

Fax +39.0577.929154

infoasf@asfenterprise.com

www.asfenterprise.com

Le misure degli articoli riportate nel presente catalogo sono puramente indicative e non costituiscono impegno determinante per la ditta costruttrice, la quale si riserva il diritto di cambiare o apportare modifiche atte a migliorare il prodotto a suo insindacabile giudizio.

The sizes of the items reported in this catalogue are purely indicative and not binding for the manufacturing company that reserves the right to change or improve the product at its own unquestionable judgement.

Alcuni prodotti presentati per la pavimentazione e la tecno-illuminazione, sono stati forniti dalla società Teykos che ringraziamo per la collaborazione.

Special thanks to Teykos Company for its collaboration in supplying some of the products presented for flooring and techno-illumination.

Concept e grafica

Edro 21

Publicato nel mese di marzo 2017 - *Published in march 2017*

